

STAR^{International} VIEW

www.starviewint.com

2017 - 2018



Think SFP,
Think **Starview**



About Starview International	04
------------------------------------	----

TERMS AND CONDITIONS	05
----------------------------	----

Transceivers

SUMMARY	07
---------------	----

SFP	10
-----------	----

SFP+	18
------------	----

GBIC	22
------------	----

X2	24
----------	----

XENPAK	26
--------------	----

XFP	28
-----------	----

QSFP	31
------------	----

CFP	34
-----------	----

Maintenance Package for Transceiver Modules	86
---	----

Calculating Fiber Loss & Distance Estimates	88
---	----

Fiber Optic Definitions	89
-------------------------------	----

Transceivers FAQ	90
------------------------	----

STARPOD FAQ	93
-------------------	----

Transceiver 3rd Party FAQ	95
---------------------------------	----

Products & Accessories

STARPOD	36
---------------	----

STARMUX	41
---------------	----

STARTAP	49
---------------	----

Cables

SUMMARY	55
---------------	----

Simplex Single Mode Patch Cord	57
--------------------------------------	----

Simplex Multi Mode Patch Cord	58
-------------------------------------	----

Duplex Single Mode Patch Cord	59
-------------------------------------	----

Duplex Multimode Patch Cord	60
-----------------------------------	----

Copper Patch Cord	61
-------------------------	----

Armour Fiber Patchcord	62
------------------------------	----

MPO Cable	64
-----------------	----

LC-HD High Density Patch Cord	66
-------------------------------------	----

Accessories

SUMMARY	68
---------------	----

Optical Connector	69
-------------------------	----

Optical Adapters	71
------------------------	----

Optical Attenuators	73
---------------------------	----

SMART Cleaners SUMMARY	75
------------------------------	----

Fiber Optic Cleaners	76
----------------------------	----

Transceiver Cleaners	77
----------------------------	----

MPO Cleaners	78
--------------------	----

PoE Extender	79
--------------------	----

PoE+ Injector	81
---------------------	----

Patch Panel	83
-------------------	----

MPO Cassette	84
--------------------	----

We look forward to hear from you.

Starview International Pte Ltd
60 Kaki Bukit Place
#05-19 Eunos Techpark
Singapore 415979
Tel: +65 3157 5338
Fax: +65 3112 8181

About Starview International

STARVIEW INTERNATIONAL (SVI)

Starview International Private Limited (SVI) is a Singapore based company specialised in manufacturing active and passive optical components used in high speed optical data networks. Our major customers are Service Providers, Enterprises and Governments.

Starview Products

SVI manufactures her own range of Starview branded products such as transceiver modules, STARPOD, STARTAP, STARMUX, optical patch cables, attenuators, couplers, and adapters.

• Transceiver modules

SVI offers a wide variety of transceiver modules such as GBIC, SFP, SFP+, XFP, XENPAK, X2, QSFP+, QSFP28, CFP, CFP2 and CFP4. All SVI transceiver modules are MSA compliant. These modules can be remotely programmed in the field using **STARPOD (Starview Programmable Optical Device)**. This unique feature provides flexibility to our customers to use a common SVI transceiver module to support multiple brands of networking equipment.

SVI also offers a wide range of optical accessories:

• STARTAP (Starview Tap)

Modular network taps to split the optical fibers with customized tap ratios for network monitoring purpose;

• STARMUX (Starview Multiplexer)

Compact passive CWDM (Coarse Wavelength Division Multiplexing) to alleviate fiber congestion. The key advantage is to combine up to 18 applications of data rates ranging from 100Mbps to 10Gbps over a single fiber core. The OADM (Optical Add Drop Multiplexing) allows applications to add-drop along the CWDM optical path;

• Optical patch cables

Pre-terminated in factory using bend-insensitive fiber to ensure reliable interconnection of the networking equipment;

• Optical accessories

Attenuators, couplers and adapters ensure reliable network communications with optimum signal quality and performance.

Starview Maintenance and Support (SMART)

SVI provides SMART services such as Help Desk, Service Level Agreements and extended warranty. Customers can activate these services via hotline, web portal and email.

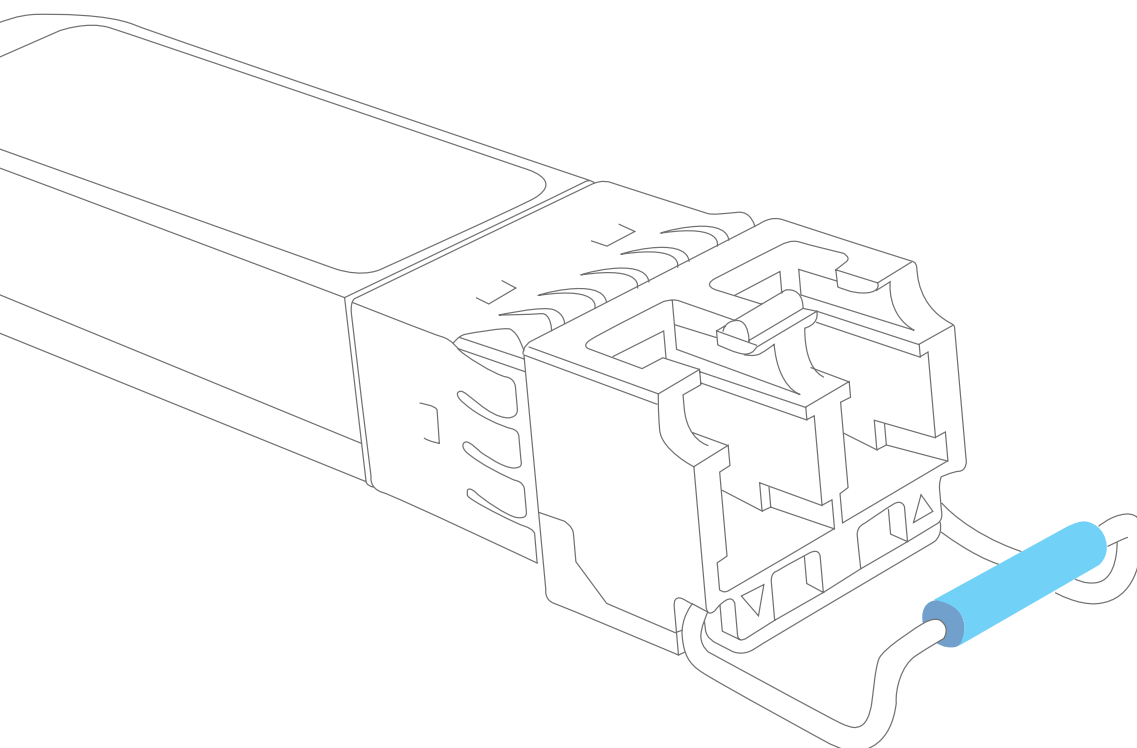

TERMS AND CONDITIONS

ORDERS:

All orders are subject to acceptance by Starview International.

All orders placed by must be confirmed in writing. Starview International Sales can provide specific delivery schedules or additional information on ordering procedures.

Office/Warehouse address:

Starview International Pte Ltd
60 Kaki Bukit Place
#05-19 Eunos Techpark
Singapore 415979
Attn: Sales (Sales@starviewint.com)

Credit Acceptance:

All orders are subject to acceptance by Starview International's Credit Department. If applicable, Starview International will establish an account and Customer will complete required forms at Starview International's request.

Payment Terms:

All payments are net in advance unless otherwise stated.

All payments are net 30 days for approved Customer in good standing.

Payments by check should be mailed to one of the following addresses, depending on your location:

US Dollar Accounts

Starview International Pte Ltd

Payments may also be made in the following manner:

Credit Card

Credit Card payment is available via Paypal. An email will be sent to the recipient for payment via credit card.

Letter of Credit

Please note that a US\$250 handling fee will be charged for orders of less than US\$25,000 that are paid for by letter of credit. All Letters of Credit must be received at least two (2) weeks prior to the scheduled shipment date.

Changes to Orders

All requests to change an order are subject to acceptance by Starview International. All requests must be made in writing, and be received at least two (2) weeks prior to the scheduled shipping date.

Prices

All prices are subject to change without notice.

Minimum Order Value

The minimum order value is US\$1,000. For any orders below US\$1,000, a processing fee of US\$30 shall be imposed. This amount is to overcome the bank charges imposed during inter-banks transfer.

RESCHEDULING, CANCELLATION AND RESTOCKING

All requests to reschedule, cancel and restock an order are subject to acceptance by Starview International. Specific fees are applicable for any rescheduling and cancellation requested less than thirty (30) days prior to a scheduled delivery date and for restocking that is requested less than thirty (30) days after receipt of the product by the Customer. Starview International will not restock if requested more than thirty (30) days after receipt of the product by the Customer.

DELIVERIES

Starview International will make reasonable efforts to meet Customer's delivery requirements. If Starview International is unable to meet Customer's delivery requirements, alternative arrangements may be agreed upon by the parties.

SHIPPING

Shipping and insurance costs are charged to the Customer's account or added to the invoice. Customs fees and duties are included in the price for products sold in Singapore only. For all other countries, Starview International's prices as indicated in the current price list are ex-works point of origin.

INSTALLATION AND ACCEPTANCE

The installation for some systems must be performed by Starview International. Following the installation, the Customer shall provide written acceptance of installed systems in accordance with Starview International's Acceptance Test Procedures.

RETURNS

All products returned to Starview International require a Return Merchandise Authorization (RMA) number. To obtain an RMA number and ship-to-address instructions, contact Starview International's Technical Support Group. Starview International will not be responsible for any product returned without an RMA number.

BASIC WARRANTY

For a period of Twenty Four (24) months from the date of shipment products are warranted under normal use:

- 1) to be free from any defect in design, material, and workmanship,
- 2) to conform strictly to specifications and approved samples, and
- 3) to be fit and sufficient for the purpose intended.

Starview International will repair or replace, free of charge, any part proven to be defective within the basic warranty period. Return-to-Customer shipping costs will be paid by Starview International for products under the basic warranty if submitted by the original purchaser. Shipping insurance is at Customer's expense. This basic warranty is standard to all Starview International products;

This warranty is in lieu of all other warranties, express, implied or statutory, including, but not limited to, the implied warranties of merchantability and fitness for a particular purpose. In no event shall Starview International be liable for special, incidental or consequential damages.

EXCEPTIONS TO BASIC WARRANTY

Starview International warranties do not cover equipment or parts subjected to misuse, negligence or accidental destruction. All consumable parts are excluded from the basic warranty.

Caution: Only Starview International's trained personnel may open the case of an instrument since permanent damage to the unit may occur. All Starview International warranties will immediately become null and void if any unauthorized third party opens an instrument case, removes the warranty sticker from across the seam of the case, removes any of the case screws, if the product serial number is altered, erased or removed, if the hardware or software is altered, if the units are not installed according to manufacturer's instructions or applicable security standards.

GENERAL INFORMATION

Starview International's head office is open from 9.00 a.m. to 18:00 p.m (GMT + 08.00)

All sales of Starview International equipment shall be governed by and interpreted in accordance with the laws applicable in Singapore, except as to (i) conflicts of laws provisions; and (ii) the reference to the Incoterm "ex-works", which incorporates into these Terms and Conditions all the current rules of the International Chamber of Commerce pertaining to the 2000 Incoterms.

Think SFP Think STARVIEW

Reprogrammable Transceiver

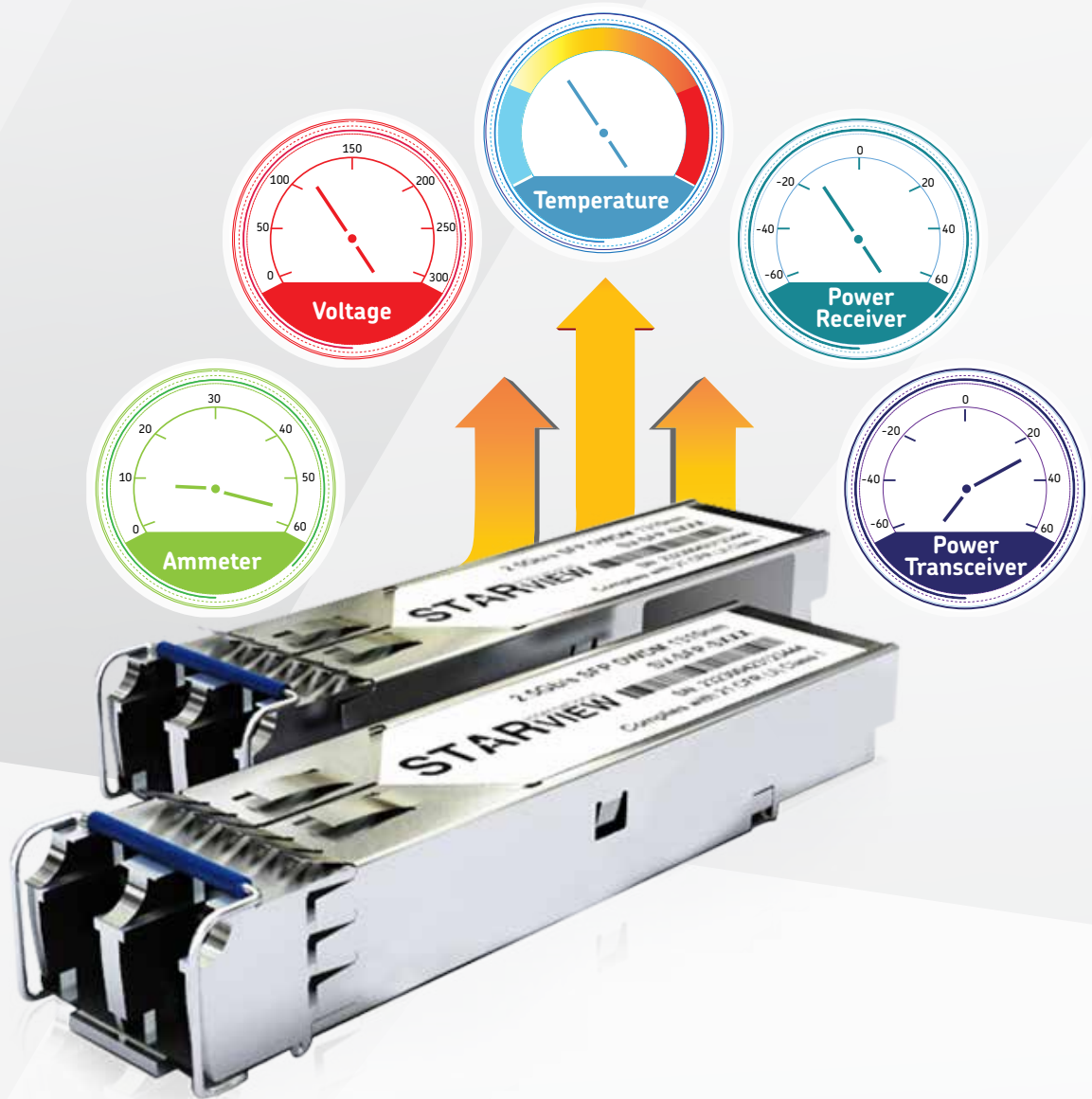

- Cost competitive and fast lead time
- Wide range and varieties of Fiber Optic Transceiver modules
- Supports Digital Diagnostic Monitoring (DDM) for optical monitoring capability compliant with SFF-8472 (Internal/ External Calibration)
- Option with normal operating temp (0 to 70°C) or Industrial temp (-40 to 85°C)
- Reprogrammable modules to interwork with major equipment vendors
- Low power consumption modules available
- Major customer references especially with Service Providers
- Warranty 2 years extendable to 5 years

Key Advantages



SVI offers a wide range of Transceiver modules with leading-edge optical components, low cost and fast lead time. All SVI transceiver modules are pre-coded before delivery to ensure inter-operability with the vendors' networking equipment, and equipped with DDM (Digital Diagnostic Monitoring) capabilities. The DDM features allow users to remotely monitor in real-time the transceiver receive optical power, transmitter optical power, laser bias current, transceiver input voltage and temperature. This function provides network manager an effective tool for implementing reliable performance monitoring of their networking devices.

SVI Transceivers are fully ROHS and MSA compliant, supports multiple network protocols to enable high speed voice, video and data communications. These applications can be used for Ethernet, Fiber Channel, 4G LTE, GPON and SONET/ SDH. SVI Transceivers are available to transmit data over Copper, Singlemode or Multimode fiber, with options to select such as transmission distances, wavelengths, power consumption and operating temperatures.

Further savings on OPEX (Operating Expenses) can be achieved with STARPOD. Using STARPOD, SVI transceiver modules are field reprogrammable to work with vendors' network equipment. SVI ensures interoperability of the transceiver module with a certificate of compatibility and money back guarantee if the module does not work.



Compatibility

Our modules are pre-configured with the standard vendor's coding before delivery



Full traffic test

Our modules are fully tested to ensure quality and reliability.



Laser color

Our modules are fully tested with Optical Spectrum Analyser to ensure the wavelength is correctly transmitted



EEPROM and label contents

All our module EEPROM is fully compatible with STARPOD for reprogramming in the field with our standard module part number



Lens inspection and clean

Our modules are fully inspected to ensure the TOSA and ROSA windows are without dust

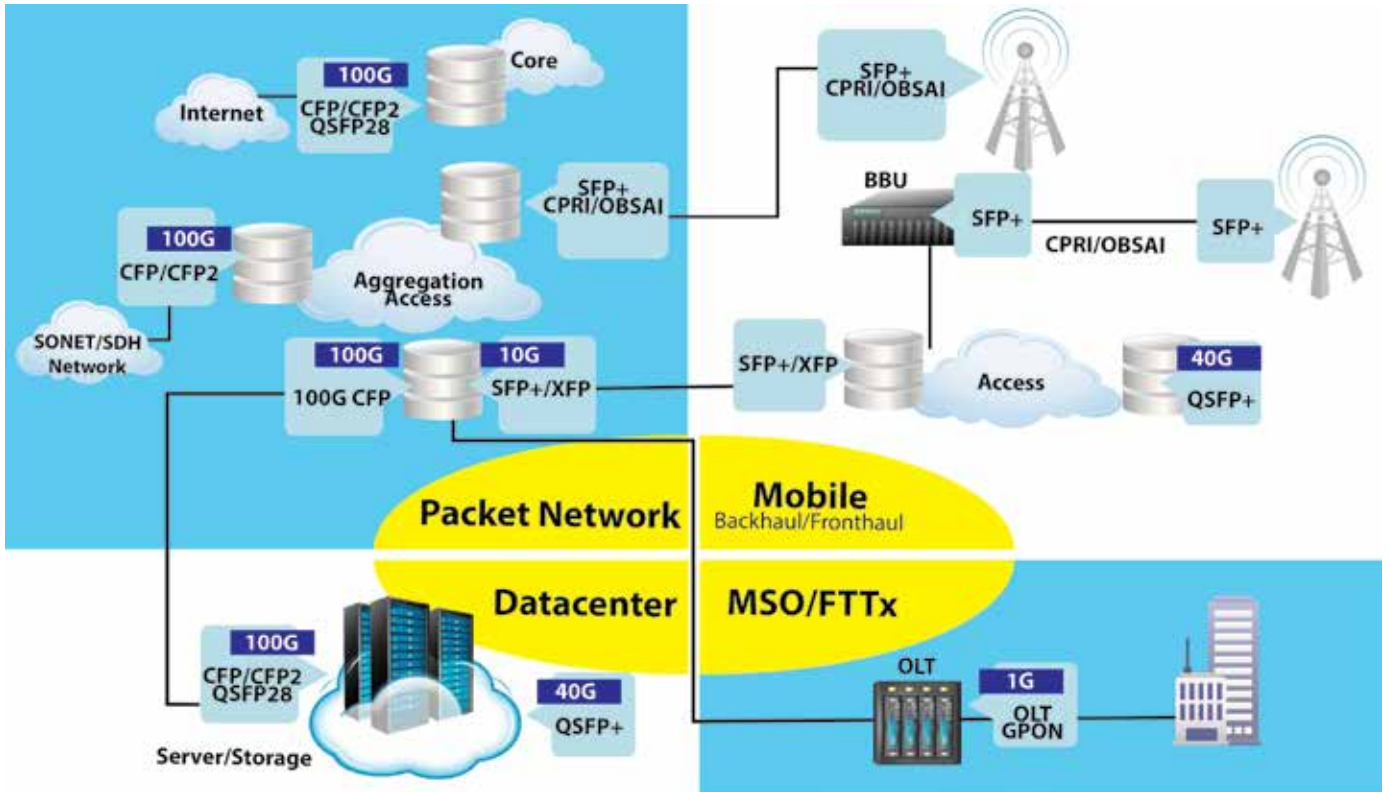

Online Transceiver Compatible Tool

This is an online tool to help you select an equivalent Starview part number. Simply enter the original manufacturer's part number to find out the equivalent Starview part number to order. You may also do a wildcard search by entering a partial part number.



Scan QR code to use Online Assistance to buy transceivers

Equipment where Starview Transceiver Modules have deployed

- CISCO
- Juniper
- Alcatel Lucent
- Extreme Networks
- Force 10
- Huawei
- HP
- H3C
- Arista Networks
- Transition Networks
- ADVA Optical Networking
- BTI
- Intel
- EXFO
- JDSU
- Allied Telesis
- Tellabs
- Nortel
- ALAXLA Networks
- Netscout
- Adtran
- Brocade
- Ericsson
- RAD
- Avaya
- NSN
- VSS Monitoring
- Gigamon
- Cyan
- Hitachi Metals
- Etc.

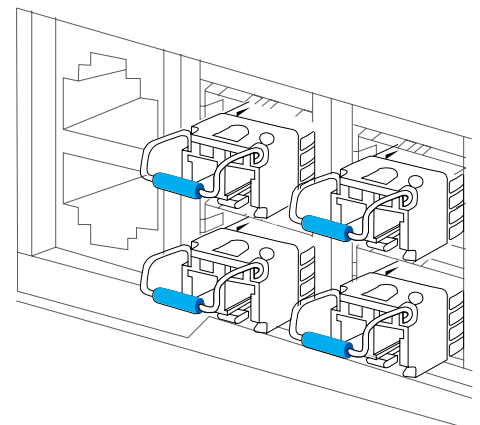

TRANSCEIVERS

Small Form Factor Pluggable **SFP**



- Copper SFP Modules
- Dual Fiber Strands SFP Modules
- CWDM Dual Fiber Strands SFP Modules
- DWDM Dual Fiber Strands SFP Modules
- Single Fiber Strand SFP Modules
- SGMII SFP Modules



Features

- Hot-Pluggable SFP Footprint
- Duplex/ Simplex LC Optical Transceiver
- Digital Diagnostic Function (optional)
- Class 1 Laser International Safety
- Standard IEC-60825 Compliant
- Compatible with SFP Multi-Sourcing Agreement (MSA)
- Copper SFP Modules
- Dual Fiber Strands SFP Modules
- CWDM Dual Fiber Strands SFP Modules
- C and L Band DWDM Dual Fiber Strands SFP Modules
- Single Fiber Strand (Bi-Di) SFP Modules

Applications

- Ethernet (100M/ 1G)
- 1G/ 2G/ 4G Fiber channel
- OC-3/12/48 or STM-1/4/16
- CPRI/ OBSAI
- Multi-rate 100Mbps to 1.25Gbps and 100Mbps to 4.25Gbps
- GPON OLT/ ONT (1.25/2.5Gbps)

SFP (small form factor pluggable) transceivers are hot-swappable in industry-standard cages and connectors, and offer high-speed performance in a compact package. SFP is used for data rates up to 4 Gb/s and DWDM.

Specifications

Standards	IEEE 802.3 2003; ANSI X3.297-1997
Dimensions	Width: 0.52" [13 mm] Depth: 2.18" [55 mm] Height: 0.33" [8 mm]
Power	3.3V
Power Consumption	0.66 Watts (fiber) 1.0 Watts (copper)
Connector Type	LC
Environment	SFP -40°C - 85°C; 0°C - 70°C
Compliance	IEC-60825; FDA 21:CFR 1040.10 and 1040.11
Warranty	2 year

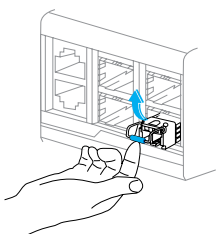

Step 1

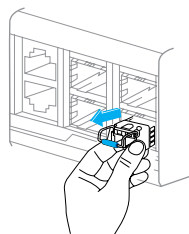

Step 2

Step 1 : Open the bale clasp on the SFP module with your index finger in a downward direction

Step 2 : Grasp the SFP module between your thumb and index finger, and carefully remove it from the switching module port

Standard temperature:

0°C to +70°C

Ordering Information

Dual Fiber Strands SFP Modules

Data Rate	Part Number	Type	Wavelength	Distance	TX Power	RX Sens.	Fiber Budget
			nm	km	dBm	dBm	dB
	SV-SFP-OC3M8D	MM	850	2	-9 to -3	-24 to -6	12
	SV-SFP-OC3MD	MM	1310	2	-24 to -14	-28 to -8	5
	SV-SFP-OC3SD2	SM	1310	20	-15 to -8	-29 to -8	14
100 Mb/s	SV-SFP-OC3SD4	SM	1310	40	-7 to -2	-32 to -10	25
(FE / STM-1 / OC-3)	SV-SFP-OC3SD8	SM	1550	80	-5 to 0	-33 to -10	28
	SV-SFP-OC3SD12	SM	1550	120	-2 to 3	-34 to -10	32
	SV-SFP-OC3SD16	SM	1550	160	1 to 5	-37 to -10	36
	SV-SFP-OC12SD2	SM	1310	20	-15 to -8	-28 to -8	13
622 Mb/s	SV-SFP-OC12SD4	SM	1310	40	-5 to 0	-28 to -8	23
(STM-4 / OC-12)	SV-SFP-OC12SD8	SM	1550	80	-3 to 2	-28 to -8	25
	SV-SFP-OC12SD12	SM	1550	120	0 to 5	-31 to -8	31
	SV-SFP-SXD	MM	850	0.22	-9 to -3	-17 to 0	5
	SV-SFP-ESXD	MM	1300	2	-5 to 0	-20 to 0	15
	SV-SFP-LXD1	SM	1310	10	-9 to -3	-20 to -3	11
	SV-SFP-LXD2	SM	1310	20	-9 to -3	-20 to -3	11
1.25 Gb/s	SV-SFP-LXD4	SM	1310	40	-5 to 0	-24 to -1	19
(Gbe / FC)	SV-SFP-ZXD6	SM	1550	60	0 to 5	-26 to -3	26
	SV-SFP-ZXD8	SM	1550	80	0 to 5	-26 to -3	26
	SV-SFP-ZXD12	SM	1550	120	0 to 5	-31 to -10	31
	SV-SFP-ZXD16	SM	1550	160	2 to 6	-34 to -10	36
	SV-SFP-2FCDSX	MM	850	0.3	-10 to -3	-18 to -3	5
2.125 Gb/s	SV-SFP-2FCLX1D	SM	1310	10	-5 to 0	-19 to 0	14
(2FC)	SV-SFP-2FCLX2D	SM	1310	20	-5 to 0	-19 to 0	14
	SV-SFP-2FCLX4D	SM	1310	40	-2 to 3	-19 to -3	17
	SV-SFP-2FCZX8D	SM	1550	80	0 to 5	-26 to -9	26
	SV-SFP-OC48SX	MM	850	0.3	-10 to -3	-18 to -3	5
	SV-SFP-OC48LXD2	SM	1310	20	-5 to 0	-19 to 0	14
2.5 Gb/s	SV-SFP-OC48LXD4	SM	1310	40	-2 to 3	-19 to -3	17
(STM-16 / OC-48)	SV-SFP-OC48ZXD4	SM	1550	40	-2 to 3	-19 to 0	17
	SV-SFP-OC48ZXD8	SM	1550	80	0 to 5	-26 to -9	26
	SV-SFP-OC48ZXD12	SM	1550	120	2 to 6	-30 to -10	32
	SV-SFP-2GSXD	MM	850	0.3	-10 to -3	-18 to -3	5
	SV-SFP-2GLXD	SM	1310	2	-9 to -3	-18 to -3	9
Multi-rate	SV-SFP-2GLXD1	SM	1310	10	-5 to 0	-19 to 0	14
100 Mb/s to 2.488 Gb/s	SV-SFP-2GLXD2	SM	1310	20	-5 to 0	-19 to 0	14
	SV-SFP-2GZXD4	SM	1550	40	-2 to 3	-19 to 0	17
	SV-SFP-2GZXD8	SM	1550	80	0 to 5	-26 to -9	26
	SV-SFP-2GZXD12	SM	1550	120	2 to 6	-30 to -10	32
	SV-SFP-4GSXD	MM	850	0.55	-9 to -2.5	-16 to 0	4
	SV-SFP-4GLXD	SM	1310	2	-6 to -1	-18 to 0.5	12
Multi-rate	SV-SFP-4GLXD1	MM	1310	10	-6 to -1	-18 to 0.5	12
100 Mb/s to 4.25 Gb/s	SV-SFP-4GLXD2	SM	1310	20	-6 to -1	-18 to 0.5	12
	SV-SFP-4GLXD4	SM	1310	40	-1 to 4	-18 to 0.5	17

Ordering Information

Standard temperature:
0°C to +70°C

Copper SFP Modules

Data Rate	Part Number	Equipment Compatibility	Distance	Interface Type	Link Auto	LOS Ground	Support TX Disable
			km				
10/100/1000Mb/s	SV-SFP-T1A	CISCO Catalyst	0.1	SGMII	Yes	Yes	No
	SV-SFP-T1B	CISCO ASR9K	0.1	SGMII	Yes	No	Yes
	SV-SFP-T1C	Alcatel	0.1	SGMII	Yes	No	No
1000Mb/s	SV-SFP-T2A	CISCO Catalyst	0.1	Serdes	No	No	No
	SV-SFP-T2B	CISCO Nexus, Huawei	0.1	Serdes	No	Yes	Yes
	SV-SFP-T2C	HP	0.1	Serdes	No	No	Yes

Single Fiber Strand SFP Modules

Data Rate	Part Number	Type	Wavelength	Distance	TX Power	RX Sens.	Fiber Budget	
			nm	km	dBm	dBm	dB	
100 Mb/s (FE / STM-1 / OC-3)	SV-SFP-OC3SD21	SM	1310 TX 1550 RX	20	-15 to -7	-28 to -8	13	
	SV-SFP-OC3SD22	SM	1550 TX 1310 RX	20	-15 to -7	-28 to -8	13	
	SV-SFP-OC3SD41	SM	1310 TX 1550 RX	40	-7 to -2	-32 to -8	25	
	SV-SFP-OC3SD42	SM	1550 TX 1310 RX	40	-7 to -2	-32 to -8	25	
	SV-SFP-OC3SD61	SM	1310 TX 1550 RX	60	-3 to +3	-32 to -3	29	
	SV-SFP-OC3SD62	SM	1550 TX 1310 RX	60	-3 to +3	-32 to -3	29	
	SV-SFP-OC3SD83	SM	1490 TX 1550 RX	80	-5 to 0	-33 to -8	28	
	SV-SFP-OC3SD84	SM	1550 TX 1490 RX	80	-5 to 0	-33 to -8	28	
	SV-SFP-OC3SD123	SM	1490 TX 1550 RX	120	-2 to 3	-34 to -10	32	
	SV-SFP-OC3SD124	SM	1550 TX 1490 RX	120	-2 to 3	-34 to -10	32	
	SV-SFP-OC3SD163	SM	1490 TX 1550 RX	160	0 to 5	-35 to -10	35	
	SV-SFP-OC3SD164	SM	1550 TX 1490 RX	160	0 to 5	-35 to -10	35	
	1.25 Gb/s (Gbe)	SV-SFP-ESXD1	MM	1310 TX 1550 RX	2	-11 to -3	-19 to -3	8
		SV-SFP-ESXD2	MM	1550 TX 1310 RX	2	-11 to -3	-19 to -3	8
		SV-SFP-LXD11	SM	1310 TX 1550 RX	10	-9 to -3	-20 to -3	11
		SV-SFP-LXD12	SM	1550 TX 1310 RX	10	-9 to -3	-20 to -3	11
SV-SFP-LXD13		SM	1310 TX 1490 RX	10	-9 to -3	-20 to -3	11	
SV-SFP-LXD14		SM	1490 TX 1310 RX	10	-9 to -3	-20 to -3	11	
SV-SFP-LXD21		SM	1310 TX 1550 RX	20	-9 to -3	-20 to -3	11	
SV-SFP-LXD22		SM	1550 TX 1310 RX	20	-9 to -3	-20 to -3	11	
SV-SFP-LXD23		SM	1310 TX 1490 RX	20	-9 to -3	-20 to -3	11	
SV-SFP-LXD24		SM	1490 TX 1310 RX	20	-9 to -3	-20 to -3	11	
SV-SFP-LXD41		SM	1310 TX 1550 RX	40	-5 to 0	-24 to 1	19	
SV-SFP-LXD42		SM	1550 TX 1310 RX	40	-5 to 0	-24 to 1	19	
SV-SFP-LXD43		SM	1310 TX 1490 RX	40	-5 to 0	-24 to 1	19	
SV-SFP-LXD44		SM	1490 TX 1310 RX	40	-5 to 0	-24 to 1	19	
SV-SFP-LXD85		SM	1550 TX 1490 RX	80	0 to 5	-26 to -3	26	
SV-SFP-LXD86		SM	1490 TX 1550 RX	80	0 to 5	-26 to -3	26	

Standard temperature:
0°C to +70°C

Ordering Information

Single Fiber Strand SFP Modules

Data Rate	Part Number	Type	Wavelength	Distance	TX Power	RX Sens.	Fiber Budget
			nm	km	dBm	dBm	dB
1.25 Gb/s	SV-SFP-LXD125	SM	1550 TX 1490 RX	120	0 to 5	-31 to -10	31
(Gbe)	SV-SFP-LXD126	SM	1490 TX 1550 RX	120	0 to 5	-31 to -10	31
	SV-SFP-1GLXD41	SM	1310 TX 1550 RX	40	-5 to 0	-24 to -1	19
Multi-rate	SV-SFP-1GLXD42	SM	1550 TX 1310 RX	40	-5 to 0	-24 to -1	19
100 Mb/s to 1.25 Gb/s	SV-SFP-1GLXD81	SM	1310 TX 1550 RX	80	0 to 5	-26 to -3	26
	SV-SFP-1GLXD82	SM	1550 TX 1310 RX	80	0 to 5	-26 to -3	26
	SV-SFP-2GLXD21	SM	1310 TX 1550 RX	20	-5 to 0	-19 to -1	14
	SV-SFP-2GLXD22	SM	1550 TX 1310 RX	20	-5 to 0	-19 to -1	14
Multi-rate	SV-SFP-2GLXD41	SM	1310 TX 1550 RX	40	-2 to 3	-19 to 0	17
100 Mb/s to 2.67 Gb/s	SV-SFP-2GLXD42	SM	1550 TX 1310 RX	40	-2 to 3	-19 to 0	17
	SV-SFP-2GLXD85	SM	1490 TX 1550 RX	80	0 to 5	-26 to -8	26
	SV-SFP-2GLXD86	SM	1550 TX 1490 RX	80	0 to 5	-26 to -8	26

C Band DWDM Dual Fiber Strands SFP Modules

100GHz Spacing Wavelength

Data Rate	Part Number	Type	Wavelength	Distance	TX Power	RX Sens.	Fiber Budget
			nm	km	dBm	dBm	dB
Multi-rate	SV-SFP-ZXD8D##	SM	DWDM Wavelength	80	0 to 4	-26 to -10	26
100 Mb/s to 1.25 Gb/s	SV-SFP-ZXD12D##	SM	DWDM Wavelength	120	0 to 5	-30 to -10	30
Multi-rate	SV-SFP-2GZXD8D##	SM	DWDM Wavelength	80	0 to 4	-28 to -10	28
100 Mb/s to 2.67 Gb/s	SV-SFP-2GZXD12D##	SM	DWDM Wavelength	120	0 to 5	-29 to -9	29

denotes DWDM 100GHz Spacing Wavelength Guide on page 86

50GHz Spacing Wavelength

Data Rate	Part Number	Type	Wavelength	Distance	TX Power	RX Sens.	Fiber Budget
			nm	km	dBm	dBm	dB
Multi-rate	SV-SFP-ZXD8AD##	SM	DWDM Wavelength	80	0 to 4	-26 to -3	26
100 Mb/s to 1.25 Gb/s	SV-SFP-ZXD12AD##	SM	DWDM Wavelength	120	0 to 5	-30 to -6	30
Multi-rate	SV-SFP-2GZXD8AD##	SM	DWDM Wavelength	80	0 to 4	-28 to -10	28
100 Mb/s to 2.67 Gb/s	SV-SFP-2GZXD12AD##	SM	DWDM Wavelength	120	0 to 5	-29 to -9	29

denotes DWDM 50GHz Spacing Wavelength Guide on page 87

Ordering Information

Standard temperature:
0°C to +70°C

CWDM Dual Fiber Strands SFP Modules

Data Rate	Part Number	Type	Wavelength	Distance	TX Power	RX Sens.	Fiber Budget
			nm	km	dBm	dBm	dB
100 Mb/s	SV-SFP-OC3SD12C##	SM	1470nm ~ 1610nm	120	-2 to 3	-34 to -10	32
(FE / STM-1 / OC-3)	SV-SFP-OC3SD16C##	SM	1450nm ~ 1610nm	160	0 to 5	-35 to -10	35
	SV-SFP-ZXD4C##	SM	1270nm ~ 1610nm	40	-5 to 0	-24 to -1	19
1.25 Gb/s	SV-SFP-ZXD8C##	SM	1270nm ~ 1610nm	80	0 to 5	-26 to -3	26
(Gbe / FC)	SV-SFP-ZXD12C##	SM	1270nm ~ 1610nm	120	0 to 5	-32 to -10	32
	SV-SFP-ZXD16C##	SM	1470nm ~ 1610nm	160	2 to 6	-34 to -10	36
100 Mb/s to 1.25 Gb/s	SV-SFP-1GZX8CD##	SM	1470nm ~ 1610nm	80	-5 to 0	-33 to -10	28
	SV-SFP-2GZX4CD##	SM	1270nm ~ 1610nm	40	-2 to 3	-19 to 0	17
Multi-rate	SV-SFP-2GZX8CD##	SM	1270nm ~ 1610nm	80	0 to 5	-28 to -9	28
100 Mb/s to 2.488 Gb/s	SV-SFP-2GZX12CD##	SM	1470nm ~ 1610nm	120	2 to 6	-30 to -10	32
100 Mb/s to 4.25 Gb/s	SV-SFP-4GZXD4C##	SM	1310nm ~ 1610nm	40	-1 to 4	-18 to 0.5	17

denotes wavelength range from 1270~1610nm.

27 = 1270nm, 29=1290nm, 31=1310nm, 33=1330nm, 35=1350nm, 37=1370nm, 39=1390nm, 41=1410nm, 43=1430nm, 45=1450nm, 47=1470nm, 49=1490nm, 51=1510nm, 53=1530nm, 55=1550nm, 57=1570nm, 59=1590nm, 61=1610nm

SGMII SFP Modules

Data Rate	Part Number	Type	Wavelength	Distance	TX Power	RX Sens.	Fiber Budget
			nm	km	dBm	dBm	dB
100 Mb/s	SV-SFP-SGLXD1		1310nm	20	-20 to -14	-31 to -10	11
	SV-SFP-SGLXD4		1310nm	40	-5 to 0	-34 to 0	29

SGMII SFP Modules - Bi-Directional

Data Rate	Part Number	Type	Wavelength	Distance	TX Power	RX Sens.	Fiber Budget
			nm	km	dBm	dBm	dB
100 Mb/s	SV-SFP-SGLXD41		1310 TX 1550 RX	40	-5 to 0	-32 to -8	27
	SV-SFP-SGLXD42		1550 RX 1310RX	40	-5 to 0	-32 to -8	27

Industrial temperature:

-40°C to +85°C

Ordering Information

Dual Fiber Strands SFP Modules

Data Rate	Part Number	Type	Wavelength	Distance	TX Power	RX Sens.	Fiber Budget
			nm	km	dBm	dBm	dB
100 Mb/s (FE / STM-1 / OC-3)	SV-SFP-OC3M8DH	MM	850	2	-9 to -3	-24 to -6	12
	SV-SFP-OC3MDH	MM	1310	2	-24 to -14	-28 to -8	5
	SV-SFP-OC3SD2H	SM	1310	20	-15 to -8	-29 to -8	14
	SV-SFP-OC3SD4H	SM	1310	40	-7 to -2	-32 to -10	25
	SV-SFP-OC3SD8H	SM	1550	80	-5 to 0	-33 to -10	28
	SV-SFP-OC3SD12H	SM	1550	120	-2 to 3	-34 to -10	32
622 Mb/s (STM-4 / OC-12)	SV-SFP-OC3SD16H	SM	1550	160	1 to 5	-37 to -10	36
	SV-SFP-OC12SD2H	SM	1310	20	-15 to -8	-28 to -8	13
	SV-SFP-OC12SD4H	SM	1310	40	-5 to 0	-28 to -8	23
	SV-SFP-OC12SD8H	SM	1550	80	-3 to 2	-28 to -8	25
	SV-SFP-OC12SD12H	SM	1550	120	0 to 5	-31 to -8	31
1.25 Gb/s (Gbe / FC)	SV-SFP-SXDH	MM	850	0.22	-9 to -3	-17 to 0	5
	SV-SFP-ESXDH	MM	1300	2	-5 to 0	-20 to 0	15
	SV-SFP-LXD1H	SM	1310	10	-9 to -3	-20 to -3	11
	SV-SFP-LXD2H	SM	1310	20	-9 to -3	-20 to -3	11
	SV-SFP-LXD4H	SM	1310	40	-5 to 0	-24 to -1	19
	SV-SFP-ZXD6H	SM	1550	60	0 to 5	-26 to -3	26
	SV-SFP-ZXD8H	SM	1550	80	0 to 5	-26 to -3	26
2.125 Gb/s (2FC)	SV-SFP-ZXD12H	SM	1550	120	0 to 5	-31 to -10	31
	SV-SFP-ZXD16H	SM	1550	160	2 to 6	-34 to -10	36
	SV-SFP-2FCDSXH	MM	850	0.3	-10 to -3	-18 to -3	5
	SV-SFP-2FCLX1DH	SM	1310	10	-5 to 0	-19 to 0	14
	SV-SFP-2FCLX2DH	SM	1310	20	-5 to 0	-19 to 0	14
2.5 Gb/s (STM-16 / OC-48)	SV-SFP-2FCLX4DH	SM	1310	40	-2 to 3	-19 to -3	17
	SV-SFP-2FCZX8DH	SM	1550	80	0 to 5	-26 to -9	26
	SV-SFP-OC48SXDH	MM	850	0.3	-10 to -3	-18 to -3	5
	SV-SFP-OC48LXD2H	SM	1310	20	-5 to 0	-19 to 0	14
	SV-SFP-OC48LXD4H	SM	1310	40	-2 to 3	-19 to -3	17
Multi-rate 100 Mb/s to 2.488 Gb/s	SV-SFP-OC48ZXD4H	SM	1550	40	-2 to 3	-19 to 0	17
	SV-SFP-OC48ZXD8H	SM	1550	80	0 to 5	-26 to -9	26
	SV-SFP-2GSXDH	MM	850	0.3	-10 to -3	-18 to -3	5
	SV-SFP-2GLXDH	SM	1310	2	-9 to -3	-18 to -3	9
	SV-SFP-2GLXD1H	SM	1310	10	-5 to 0	-19 to 0	14
Multi-rate 100 Mb/s to 4.25 Gb/s	SV-SFP-2GLXD2H	SM	1310	20	-5 to 0	-19 to 0	14
	SV-SFP-2GZXD4H	SM	1550	40	-2 to 3	-19 to 0	17
	SV-SFP-2GZXD8H	SM	1550	80	0 to 5	-26 to -9	26
	SV-SFP-4GSXDH	MM	850	0.55	-9 to -2.5	-16 to 0	4
Multi-rate 100 Mb/s to 4.25 Gb/s	SV-SFP-4GLXDH	SM	1310	2	-6 to -1	-18 to 0.5	12
	SV-SFP-4GLXD1H	MM	1310	10	-6 to -1	-18 to 0.5	12
	SV-SFP-4GLXD2H	SM	1310	20	-6 to -1	-18 to 0.5	12
	SV-SFP-4GLXD4H	SM	1310	40	-1 to 4	-18 to 0.5	17

Ordering Information

Industrial temperature:
-40°C to +85°C

Copper SFP Modules

Data Rate	Part Number	Equipment Compatibility	Distance	Interface Type	Link Auto	LOS Ground	Support TX Disable
			km				
10/100/1000Mb/s	SV-SFP-T1AH	CISCO Catalyst	0.1	SGMII	Yes	Yes	No
	SV-SFP-T1BH	CISCO ASR9K	0.1	SGMII	Yes	No	Yes
	SV-SFP-T1CH	Alcatel	0.1	SGMII	Yes	No	No
1000Mb/s	SV-SFP-T2AH	CISCO Catalyst	0.1	Serdes	No	No	No
	SV-SFP-T2BH	CISCO Nexus, Huawei	0.1	Serdes	No	Yes	Yes
	SV-SFP-T2CH	HP	0.1	Serdes	No	No	Yes

Single Fiber Strand SFP Modules

Data Rate	Part Number	Type	Wavelength	Distance	TX Power	RX Sens.	Fiber Budget
			nm	km	dBm	dBm	dB
100 Mb/s (FE / STM-1 / OC-3)	SV-SFP-OC3SD21H	SM	1310 TX 1550 RX	20	-15 to -7	-28 to -8	13
	SV-SFP-OC3SD22H	SM	1550 TX 1310 RX	20	-15 to -7	-28 to -8	13
	SV-SFP-OC3SD41H	SM	1310 TX 1550 RX	40	-7 to -2	-32 to -8	25
	SV-SFP-OC3SD42H	SM	1550 TX 1310 RX	40	-7 to -2	-32 to -8	25
	SV-SFP-OC3SD61H	SM	1310 TX 1550 RX	60	-3 to +3	-32 to -3	29
	SV-SFP-OC3SD62H	SM	1550 TX 1310 RX	60	-3 to +3	-32 to -3	29
	SV-SFP-OC3SD83H	SM	1490 TX 1550 RX	80	-5 to 0	-33 to -8	28
	SV-SFP-OC3SD84H	SM	1550 TX 1490 RX	80	-5 to 0	-33 to -8	28
	SV-SFP-OC3SD123H	SM	1490 TX 1550 RX	120	-2 to 3	-34 to -10	32
	SV-SFP-OC3SD124H	SM	1550 TX 1490 RX	120	-2 to 3	-34 to -10	32
1.25 Gb/s (Gbe)	SV-SFP-ESXD1H	MM	1310 TX 1550 RX	2	-11 to -3	-19 to -3	8
	SV-SFP-ESXD2H	MM	1550 TX 1310 RX	2	-11 to -3	-19 to -3	8
	SV-SFP-LXD11H	SM	1310 TX 1550 RX	10	-9 to -3	-20 to -3	11
	SV-SFP-LXD12H	SM	1550 TX 1310 RX	10	-9 to -3	-20 to -3	11
	SV-SFP-LXD13H	SM	1310 TX 1490 RX	10	-9 to -3	-20 to -3	11
	SV-SFP-LXD14H	SM	1490 TX 1310 RX	10	-9 to -3	-20 to -3	11
	SV-SFP-LXD21H	SM	1310 TX 1550 RX	20	-9 to -3	-20 to -3	11
	SV-SFP-LXD22H	SM	1550 TX 1310 RX	20	-9 to -3	-20 to -3	11
	SV-SFP-LXD23H	SM	1310 TX 1490 RX	20	-9 to -3	-20 to -3	11
	SV-SFP-LXD24H	SM	1490 TX 1310 RX	20	-9 to -3	-20 to -3	11
	SV-SFP-LXD41H	SM	1310 TX 1550 RX	40	-5 to 0	-24 to 1	19
	SV-SFP-LXD42H	SM	1550 TX 1310 RX	40	-5 to 0	-24 to 1	19
	SV-SFP-LXD43H	SM	1310 TX 1490 RX	40	-5 to 0	-24 to 1	19
	SV-SFP-LXD44H	SM	1490 TX 1310 RX	40	-5 to 0	-24 to 1	19
	SV-SFP-LXD85H	SM	1550 TX 1490 RX	80	0 to 5	-26 to -3	26
	SV-SFP-LXD86H	SM	1490 TX 1550 RX	80	0 to 5	-26 to -3	26

Industrial temperature:

-40°C to +85°C

Ordering Information

Single Fiber Strand SFP Modules

Data Rate	Part Number	Type	Wavelength	Distance	TX Power	RX Sens.	Fiber Budget
			nm	km	dBm	dBm	dB
1.25 Gb/s	SV-SFP-LXD125H	SM	1550 TX 1490 RX	120	0 to 5	-31 to -10	31
(Gbe)	SV-SFP-LXD126H	SM	1490 TX 1550 RX	120	0 to 5	-31 to -10	31
	SV-SFP-1GLXD41H	SM	1310 TX 1550 RX	40	-5 to 0	-24 to -1	19
Multi-rate	SV-SFP-1GLXD42H	SM	1550 TX 1310 RX	40	-5 to 0	-24 to -1	19
100 Mb/s to 1.25 Gb/s	SV-SFP-1GLXD81H	SM	1310 TX 1550 RX	80	0 to 5	-26 to -3	26
	SV-SFP-1GLXD82H	SM	1550 TX 1310 RX	80	0 to 5	-26 to -3	26
	SV-SFP-2GLXD21H	SM	1310 TX 1550 RX	20	-5 to 0	-19 to -1	14
	SV-SFP-2GLXD22H	SM	1550 TX 1310 RX	20	-5 to 0	-19 to -1	14
Multi-rate	SV-SFP-2GLXD41H	SM	1310 TX 1550 RX	40	-2 to 3	-19 to 0	17
100 Mb/s to 2.67 Gb/s	SV-SFP-2GLXD42H	SM	1550 TX 1310 RX	40	-2 to 3	-19 to 0	17
	SV-SFP-2GLXD85H	SM	1490 TX 1550 RX	80	0 to 5	-26 to -8	26
	SV-SFP-2GLXD86H	SM	1550 TX 1490 RX	80	0 to 5	-26 to -8	26

TRANSCEIVERS

Small Form Pluggable Plus **SFP+**



- Active Optical Cable
- Dual Fiber Strands SFP+ Modules
- CPRI / OBSAI SFP+ Modules
- Single Fiber Strand SFP+ Modules
- CWDM Dual Fiber Strands SFP+ Modules
- C and L Band DWDM Dual Fiber Strands SFP+ Modules



Features

- Hot-Pluggable SFP+ Footprint
- Duplex/ Simplex LC Optical Transceiver
- Digital Diagnostic Function
- Class 1 Laser International Safety
- Standard IEC-60825 Compliant
- Compatible with SFP+ Multi-Sourcing Agreement (MSA)
- Dual Fiber Strands SFP+ Modules
- CWDM Dual Strands SFP+ Modules
- C Band DWDM Dual Fiber Strands SFP+ Modules
- Single Fiber Strand (Bi-Di) SFP+ Modules

Applications

- OC192/STM64
- 1/10G Ethernet
- 1/2/4/8G Fiber Channel
- CPRI and OBSAI (1.25Gbps to 6.25Gbps)

SFP+(Enhanced SFP) is a standardized form factor for fiber optic transceivers and is used in datacom and telecom optical links, offering a smaller footprint and lower power consumption than XFP transceivers. Initial standard applications focused on 8G Fibre Channel, 10G Ethernet and 10G Fibre Channel, where the electrical interface to the host board is a standardized serial interface called SFI. The applications have expanded to include SONET OC-192, SDH STM-64, OTN G.709, CPRI wireless, 16G Fibre Channel, and the emerging 32G Fibre Channel application.

Specifications

Standards	IEEE 802.3 2003; ANSI X3.297-1997
Dimensions	Width: 0.52" [13 mm] Depth: 2.18" [55 mm] Height: 0.33" [8 mm]
Power	3.3V
Power Consumption	0.66 Watts (fiber) 1.0 Watts (copper)
Connector Type	LC
Environment	SFP+ -5°C - 85°C; 0°C - 70°C
Compliance	IEC-60825; FDA 21;CFR 1040.10 and 1040.11
Warranty	2 year

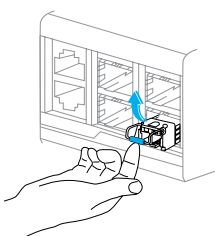

Step 1

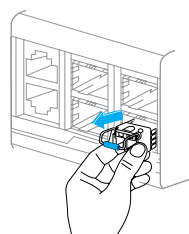

Step 2

Step 1 : Open the bale clasp on the SFP module with your index finger in a downward direction

Step 2 : Grasp the SFP module between your thumb and index finger, and carefully remove it from the switching module port

Standard temperature:
0°C to +70°C

Ordering Information

Active Optical Cables

Data Rate	Part Number	Type	Wavelength	Distance	TX Power	RX Sens.	Fiber Budget
			nm	km	dBm	dBm	dB
	SV-SFPP-10GT3-T3-1M			1			
	SV-SFPP-10GT3-T3-3M			3			
1/10 GbE	SV-SFPP-10GT3-T3-5M			5			
1/ 2/ 4/ 8 (FC)	SV-SFPP-10GT3-T3-7M			7			
	SV-SFPP-10GT3-T3-10M			10			
	SV-SFPP-10GT3-T3-15M			15			

Dual Fiber Strands SFP+ Modules

Data Rate	Part Number	Type	Wavelength	Distance	TX Power	RX Sens.	Fiber Budget
			nm	km	dBm	dBm	dB
	SV-SFPP-8GSRD	MM	850	0.15	-6 to -1	-10 to 0.5	1
	SV-SFPP-8GESRD	MM	1300	0.22	-6.5 to 0.5	-10 to 1.5	0.5
Fiber Channel	SV-SFPP-8GLRD1	SM	1310	10	-6 to -1	-15 to 0.5	9
1/ 2/ 4/ 8 (FC)	SV-SFPP-8GLRD2	SM	1310	20	-6 to -1	-15 to 0.5	9
	SV-SFPP-8GERD4	SM	1550	40	-1 to 3	-16 to 0.5	15
	SV-SFPP-8GZRD8	SM	1550	80	0 to 4	-23 to -6	23
	SV-SFPP-10GSRD	MM	850	0.3	-6 to -1	-10 to 0.5	1
	SV-SFPP-10GESRD	MM	1300	0.22	-6.5 to 0.5	-10 to 1.5	0.5
	SV-SFPP-10GLRD	SM	1310	2	-8.2 to 0.5	-14.4 to 0.5	6.2
1/10 GbE	SV-SFPP-10GLRD1	SM	1310	10	-6 to -1	-14.4 to 0.5	8.4
1/ 2/ 4/ 8 (FC)	SV-SFPP-10GLRD2	SM	1310	20	-6 to -1	-14.4 to 0.5	8.4
	SV-SFPP-10GERD4	SM	1550	40	-1 to 3	-15.8 to 0.5	14.8
	SV-SFPP-10GERD8	SM	1550	80	0 to 4	-23 to -7	23
	SV-SFPP-10GERD8(LP)*	SM	1550	80	0 to 4	-23 to -7	23

*LP denotes low power consumption

CWDM Dual Fiber Strands SFP+ Modules

Data Rate	Part Number	Type	Wavelength	Distance	TX Power	RX Sens.	Fiber Budget
			nm	km	dBm	dBm	dB
Fiber Channel	SV-SFPP-8GERD4C##	SM	1270 - 1610	40	0 to 5	-16 to 0.5	16
1/ 2/ 4/ 8 (FC)	SV-SFPP-8GERD8C##	SM	1470 - 1610	80	0 to 4	-23 to -7	23
1 / 10 GbE	SV-SFPP-10GERD4C##	SM	1270 - 1610	40	-1 to 3	-15 to 0.5	14
1/ 2/ 4/ 8 (FC)	SV-SFPP-10GERD8C##	SM	1470 - 1610	80	0 to 4	-23 to -7	23

denotes wavelength range from 1270-1610nm.

27 = 1270nm, 29=1290nm, 31=1310nm, 33=1330nm, 35=1350nm, 37=1370nm, 39=1390nm, 41=1410nm, 43=1430nm, 45=1450nm, 47=1470nm, 49=1490nm, 51=1510nm, 53=1530nm, 55=1550nm,57=1570nm, 59=1590nm, 61=1610nm

Ordering Information

Standard temperature:
0°C to +70°C

C Band DWDM Dual Fiber Strands SFP+ Modules

100GHz Spacing Wavelength

Data Rate	Part Number	Type	Wavelength	Distance	TX Power	RX Sens.	Fiber Budget
			nm	km	dBm	dBm	dB
1 / 10 GbE	SV-SFPP-10GERD4D##	SM	DWDM Wavelength	40	-1 to 3	-15.8 to 0.5	14.8
1/2/4/8 (FC)	SV-SFPP-10GERD8D##	SM	DWDM Wavelength	80	0 to 4	-23 to -7	23

denotes DWDM 100GHz Spacing Wavelength Guide on page 86

50GHz Spacing Wavelength

Data Rate	Part Number	Type	Wavelength	Distance	TX Power	RX Sens.	Fiber Budget
			nm	km	dBm	dBm	dB
1 / 10 GbE	SV-SFPP-10GERD4AD##	SM	DWDM Wavelength	40	-1 to 3	-15.8 to 0.5	14.8
1/2/4/8 (FC)	SV-SFPP-10GERD8AD##	SM	DWDM Wavelength	80	-1 to 4	-23 to -6	22
	SV-SFPP-ZXDA8DT	SM	Tunable DWDM Wavelength	80	-1 to 3	-27 to -6	26

denotes DWDM 50GHz Spacing Wavelength Guide on page 87

Single Fiber Strand SFP+ Modules

Data Rate	Part Number	Type	Wavelength	Distance	TX Power	RX Sens.	Fiber Budget
			nm	km	dBm	dBm	dB
	SV-SFPP-10GLRD11	SM	1270 TX 1330 RX	10	-6 to -1	-14.4 to 0.5	8.4
	SV-SFPP-10GLRD12	SM	1330 TX 1270 RX	10	-6 to -1	-14.4 to 0.5	8.4
	SV-SFPP-10GLRD21	SM	1270 TX 1330 RX	20	-6 to -0.5	-15 to 0.5	9
1/10 GbE	SV-SFPP-10GLRD22	SM	1330 TX 1270 RX	20	-6 to -0.5	-15 to 0.5	9
1/2/4/8 (FC)	SV-SFPP-10GLRD41	SM	1270 TX 1330 RX	40	0 to 5	-15 to 0.5	15
	SV-SFPP-10GLRD42	SM	1330 TX 1270 RX	40	0 to 5	-15 to 0.5	15
	SV-SFPP-10GLRD61	SM	1270 TX 1330 RX	60	0 to 5	-20 to -6	20
	SV-SFPP-10GLRD62	SM	1330 TX 1270 RX	60	0 to 5	-20 to -6	20
	SV-SFPP-10GLRD85	SM	1550 TX 1490 RX	80	0 to 5	-23 to -6	23
	SV-SFPP-10GLRD86	SM	1490 TX 1550 RX	80	0 to 5	-23 to -6	23

Industrial temperature:
-5°C to +85°C

Ordering Information

Dual Fiber Strands SFP+ Modules

Data Rate	Part Number	Type	Wavelength	Distance	TX Power	RX Sens.	Fiber Budget
			nm	km	dBm	dBm	dB
	SV-SFPP-8GSRDH	MM	850	0.15	-6 to -1	-10 to 0.5	1
	SV-SFPP-8GESRDH	MM	1300	0.22	-6.5 to 0.5	-10 to 1.5	0.5
Fiber Channel	SV-SFPP-8GLRD1H	SM	1310	10	-6 to -1	-15 to 0.5	9
1/ 2/ 4/ 8 (FC)	SV-SFPP-8GLRD2H	SM	1310	20	-6 to -1	-15 to 0.5	9
	SV-SFPP-8GERD4H	SM	1550	40	-1 to 3	-16 to 0.5	15
	SV-SFPP-8GZRD8H	SM	1550	80	0 to 4	-23 to -6	23
	SV-SFPP-10GSRDH	MM	850	0.3	-6 to -1	-10 to 0.5	1
	SV-SFPP-10GESRDH	MM	1300	0.22	-6.5 to 0.5	-10 to 1.5	0.5
	SV-SFPP-10GLRDH	SM	1310	2	-8.2 to 0.5	-14.4 to 0.5	6.2
1/10 GbE	SV-SFPP-10GLRD1H	SM	1310	10	-6 to -1	-14.4 to 0.5	8.4
1/ 2/ 4/ 8 (FC)	SV-SFPP-10GLRD2H	SM	1310	20	-6 to -1	-14.4 to 0.5	8.4
	SV-SFPP-10GERD4H	SM	1550	40	-1 to 3	-15.8 to 0.5	14.8
	SV-SFPP-10GERD8H	SM	1550	80	0 to 4	-23 to -7	23

CPRI / OBSAI SFP+ Modules

CPRI Modules

Data Rate	Part Number	Type	Wavelength	Distance	TX Power	RX Sens.	Fiber Budget
			nm	km	dBm	dBm	dB
	SV-SFPP-6GSRDH	SM	850	0.3	-6 to -1	-15 to -1	6
Multi-rate	SV-SFPP-6GLRDH	SM	1310	2	-6.5 to 0.5	-14.4 to 0.5	7.9
1.25Gb/s to	SV-SFPP-6GLRD1H	SM	1310	10	-8.2 to 0.5	-14.4 to 0.5	6.2
6.25Gb/s	SV-SFPP-6GLRD2H	SM	1310	20	-8.2 to 0.5	-14.4 to 0.5	6.2
	SV-SFPP-6GLRD4H	SM	1550	40	-3 to 3	-14.1 to -1	11.1
	SV-SFPP-6GLRD8H	SM	1550	80	0 to 4	-24 to -7	24

CWDM CPRI Modules

Data Rate	Part Number	Type	Wavelength	Distance	TX Power	RX Sens.	Fiber Budget
			nm	km	dBm	dBm	dB
Multi-rate	SV-SFPP-6GERD4C##	SM	1270 - 1610	40	0 to 5	-16 to 0.5	16
1.25Gb/s to 6.25Gb/s	SV-SFPP-6GERD8C##	SM	1270 - 1610	80	0 to 4	-23 to -7	23

denotes wavelength range from 1270-1610nm.

27 = 1270nm, 29=1290nm, 31=1310nm, 33=1330nm, 35=1350nm, 37=1370nm, 39=1390nm, 41=1410nm, 43=1430nm, 45=1450nm, 47=1470nm, 49=1490nm, 51=1510nm, 53=1530nm, 55=1550nm,57=1570nm, 59=1590nm, 61=1610nm

TRANSCEIVERS

Giga-Bit Interface Converter **GBIC**



- Copper GBIC Modules
- Dual Fiber Strands GBIC Modules
- CWDM Dual Fiber Strands GBIC Modules
- Single Fiber Strand (Bi-Di) GBIC Modules



Features

- Laser Class 1 Product
- Compliant with 802.3z 1000BASE-SX;
- 1000BASE-LX
- Plug-and-Play module
- Hot-swappable
- TTL Logic Interface
- Copper GBIC Modules
- Dual Fiber Strands GBIC Modules
- CWDM Dual Fiber Strands GBIC Modules
- Single Fiber Strand (Bi-Di) GBIC Modules

Applications

- Gigabit Ethernet
- 1G Fiber channel

A gigabit interface converter (GBIC) is a standard for transceivers, commonly used with Gigabit Ethernet and fibre channel in the 2000s. By offering a standard, hot swappable electrical interface, one gigabit port can support a wide range of physical media, from copper to long-wave single-mode optical fiber, at lengths of tens of kilometers.

Specifications

Standards	IEEE 802.3z 1000BASE-SX; 1000BASE-LX
Dimensions	Width: 1.2" [30 mm] Depth: 2.6" [65 mm] Height: 0.40" [10 mm]
Power	5V, no external power required
Power Consumption	0.8 Watts
Connector Type	SC
Environment	0°C - 70°C
Compliance	UL Registered, CSA, IEC 60825-1 and IEC 60825-2, CE Mark
Warranty	2 year

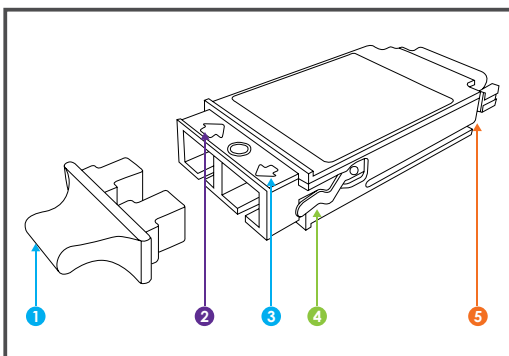

1	Optical bore dust plug	4	Spring clip
2	Receive optical bore	5	Alignment groove
3	Transmit optical bore	--	-----

Ordering Information

Copper GBIC Modules

Data Rate	Part Number	Type	Wavelength	Distance	TX Power	RX Sens.	Fiber Budget
			nm	km	dBm	dBm	dB
1 Gb/s	SV-GB-T2			0.1			

Dual Fiber Strands GBIC Modules

Data Rate	Part Number	Type	Wavelength	Distance	TX Power	RX Sens.	Fiber Budget
			nm	km	dBm	dBm	dB
	SV-GB-SX	MM	850	0.55	-9 to -3	-18 to 0	6
	SV-GB-LX1	SM	1310	10	-9 to -3	-20 to -3	11
1 Gb/s	SV-GB-LX2	SM	1310	20	-9 to -3	-20 to -3	11
	SV-GB-LX4	SM	1310	40	-5 to 0	-24 to -1	19
	SV-GB-LX8	SM	1550	80	0 to 5	-26 to -3	26

CWDM Dual Fiber Strands GBIC Modules

Data Rate	Part Number	Type	Wavelength	Distance	TX Power	RX Sens.	Fiber Budget
			nm	km	dBm	dBm	dB
	SV-GB-LX4C##	SM	1270 ~ 1610	40	-5 to 0	-24 to -3	19
1 Gb/s	SV-GB-LX8C##	SM	1270 ~ 1610	80	0 to 5	-26 to -3	26

denotes wavelength range from 1270-1610nm.

27 = 1270nm, 29=1290nm, 31=1310nm, 33=1330nm, 35=1350nm, 37=1370nm, 39=1390nm, 41=1410nm, 43=1430nm, 45=1450nm, 47=1470nm, 49=1490nm, 51=1510nm, 53=1530nm, 55=1550nm, 57=1570nm, 59=1590nm, 61=1610nm

Single Fiber Strand GBIC Modules

Data Rate	Part Number	Type	Wavelength	Distance	TX Power	RX Sens.	Fiber Budget
			nm	km	dBm	dBm	dB
	SV-GB-ESX1	SM	1310 TX 1550 RX	2	-11 to -3	-20 to -3	9
	SV-GB-ESX2	SM	1550 TX 1310 RX	2	-11 to -3	-20 to -3	9
	SV-GB-LX21	SM	1310 TX 1550 RX	20	-9 to -3	-20 to -1	11
	SV-GB-LX22	SM	1550 TX 1310 RX	20	-9 to -3	-20 to -1	11
	SV-GB-LX23	SM	1310 TX 1490 RX	20	-5 to 0	-24 to -1	19
1 Gb/s	SV-GB-LX24	SM	1490 TX 1310 RX	20	-5 to 0	-24 to -1	19
	SV-GB-LX41	SM	1310 TX 1550 RX	40	-5 to 0	-24 to -1	19
	SV-GB-LX42	SM	1550 TX 1310 RX	40	-5 to 0	-24 to -1	19
	SV-GB-LX43	SM	1310 TX 1490 RX	40	-5 to 0	-24 to -1	19
	SV-GB-LX44	SM	1490 TX 1310 RX	40	-5 to 0	-24 to -1	19

TRANSCEIVERS

10-Gigabit Ethernet Transceiver Modules **X2**

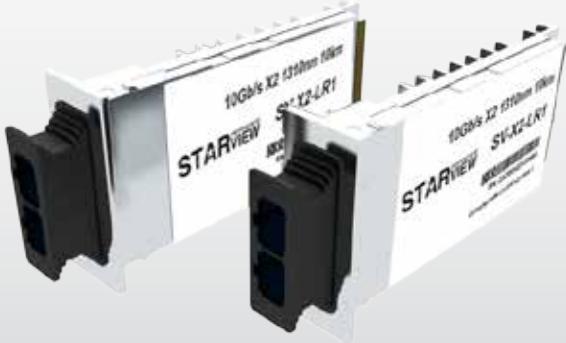

- Dual Fiber Strands X2 Modules
- CWDM Dual Fiber Strands X2 Modules
- DWDM Dual Fiber Strands X2 Modules



Features

- Data Rates: 10Gbps
- Compatible with X2 MSA Rev2.0b
- Compliant with 802.3ae 10GBASE-LR at 10.3125Gbps
- Hot Pluggable 70-PIN Connector with XAU1 Electrical Interface
- Management and control via MDIO 2-wire interface
- Power Supply: +3.3V, APS(+1.2V)
- Diagnostic Optics Monitoring
- Temperature Range: 0-70°C
- Dual Fiber Strands X2 Modules
- CWDM Dual Strands X2 Modules
- C Band DWDM Dual Fiber Strands X2 Module

Applications

- Supports 10G Ethernet 10.312Gbps

X2 is a standardized form factor for 10 Gb/s fiber optics transponders. X2 transponders are used in datacom optical links, primarily 10G Ethernet.

Specifications

Standards	IEEE 802.3z 1000BASE-SX; 1000BASE-LX
Dimensions	1.4" [36 mm] Depth: 3.5" [91 mm] Height: 0.50" [13 mm]
Power	5V
Power Consumption	0.8 Watts
Connector Type	SC
Environment	0°C – 70°C
Compliance	UL Registered, CSA, IEC 60825-1 and IEC
Warranty	2 year

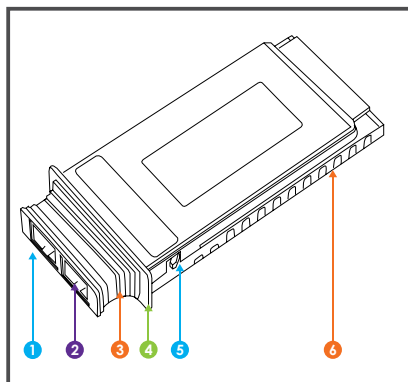

1	Transmit optical bore	4	EMI gasket flange
2	Receive optical bore	5	Latch
3	Latching sleeve	6	Transceiver heat sink

Ordering Information

Dual Fiber Strands X2 Modules

Data Rate	Part Number	Type	Wavelength	Distance	TX Power	RX Sens.	Fiber Budget
			nm	km	dBm	dBm	dB
	SV-X2-SR	MM	850	0.3	-7.3 to -1.3	-9 to 0.5	1.7
	SV-X2-LR1	SM	1310	10	-5 to -0.5	-14.4 to 0.5	9.4
10 Gb/s	SV-X2-ER4	SM	1550	40	-1 to 4	-16.5 to 0.5	15.5
	SV-X2-ZR8	SM	1550	80	0 to 5	-24 to 0.5	24

CWDM Dual Fiber Strands X2 Modules

Data Rate	Part Number	Type	Wavelength	Distance	TX Power	RX Sens.	Fiber Budget
			nm	km	dBm	dBm	dB
	SV-X2-ER4C##	SM	1470 ~ 1610	40	-1 to 4	-16.5 to 0.5	15.5
10 Gb/s	SV-X2-ZR8C##	SM	1470 ~ 1610	80	0 to 5	-24 to 0.5	24

denotes wavelength range from 1270-1610nm.
 27 = 1270nm, 29=1290nm, 31=1310nm, 33=1330nm, 35=1350nm, 37=1370nm, 39=1390nm, 41=1410nm, 43=1430nm, 45=1450nm,
 47=1470nm, 49=1490nm, 51=1510nm, 53=1530nm, 55=1550nm,57=1570nm, 59=1590nm, 61=1610nm

C-Band DWDM Dual Fiber Strands X2 Modules

Data Rate	Part Number	Type	Wavelength	Distance	TX Power	RX Sens.	Fiber Budget
			nm	km	dBm	dBm	dB
	SV-X2-10GER4D##	SM	DWDM Wavelength	40	-1 to 4	-16.5 to 0.5	15.5
10 Gb/s	SV-X2-10GER8D##	SM	DWDM Wavelength	80	0 to 5	-24 to 0.5	24

denotes DWDM 100GHz Spacing Wavelength Guide on page 86

TRANSCEIVERS

XENPAK

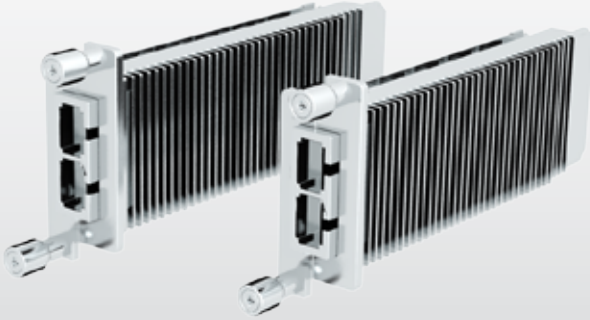

- Dual Fiber Strands XENPAK Modules
- CWDM Dual Fiber Strands XENPAK Modules
- DWDM Dual Fiber Strands XENPAK Modules



Features

- Data Rates: 10Gbps
- Compatible with XENPAK MSA Rev3.0
- Support of IEEE 802.3ae 10GBASE-LR
- Plug-and-Play module
- Hot Pluggable 70-PIN Connector with XAU1 Electrical Interface
- Management and control via MDIO 2-wire interface
- Adaptable Power Supply (APS:+1.2V)
- SC duplex Optical connector
- Dual Fiber Strands XENPAK Modules
- CWDM Dual Strands XENPAK Modules
- C Band DWDM Dual Fiber Strands XENPAK Modules

Applications

- Supports 10G Ethernet 10.312Gbps

XENPAK is a standardized form factor for 10 Gb/s fiber optics transponders. XENPAK transponders are used in datacom optical links, primarily 10G Ethernet.

Specifications

Standards	IEEE 802.3z 1000BASE-SX; 1000BASE-LX
Dimensions	1.42" [36 mm] Depth: 4.76" [121 mm] Height: 0.47" [18 mm]
Power	5V
Power Consumption	0.8 Watts
Connector Type	SC
Environment	0°C – 70°C
Compliance	UL Registered, CSA, IEC 60825-1 and IEC 60825-2, CE Mark
Warranty	2 year

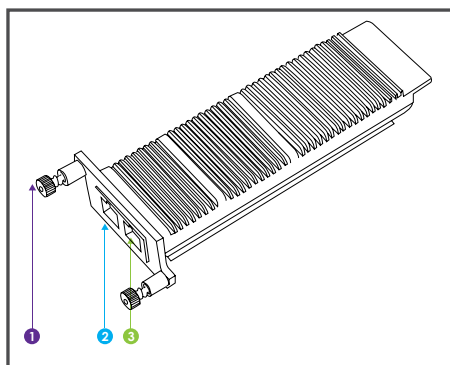

1	Captive installation screw
2	Transmit optical bore
3	Receive optical bore

Ordering Information

Dual Fiber Strands XENPAK Modules

Data Rate	Part Number	Type	Wavelength	Distance	TX Power	RX Sens.	Fiber Budget
			nm	km	dBm	dBm	dB
	SV-XENPAK-SR	MM	850	0.3	-7.3 to -1.3	-9 to 0.5	1.7
	SV-XENPAK-LR1	SM	1310	10	-5 to 0.5	-14.4 to 0.5	9.4
10 Gb/s	SV-XENPAK-ER4	SM	1550	40	-1 to 4	-16.5 to 0.5	15.5
	SV-XENPAK-ZR8	SM	1550	80	0 to 5	-24 to 0.5	24

CWDM Dual Fiber Strands XENPAK Modules

Data Rate	Part Number	Type	Wavelength	Distance	TX Power	RX Sens.	Fiber Budget
			nm	km	dBm	dBm	dB
	SV-XENPAK-ER4C##	SM	1470 ~ 1610	40	-1 to 4	-16.5 to 0.5	15.5
10 Gb/s	SV-XENPAK-ZR8C##	SM	1470 ~ 1610	80	0 to 5	-24 to 0.5	24

denotes wavelength range from 1270-1610nm.
 27 = 1270nm, 29=1290nm, 31=1310nm, 33=1330nm, 35=1350nm, 37=1370nm, 39=1390nm, 41=1410nm, 43=1430nm, 45=1450nm,
 47=1470nm, 49=1490nm, 51=1510nm, 53=1530nm, 55=1550nm,57=1570nm, 59=1590nm, 61=1610nm

C-Band DWDM Dual Fiber Strands XENPAK Modules

Data Rate	Part Number	Type	Wavelength	Distance	TX Power	RX Sens.	Fiber Budget
			nm	km	dBm	dBm	dB
	SV-X2-10GER4D##	SM	DWDM Wavelength	40	-1 to 4	-16.5 to 0.5	15.5
10 Gb/s	SV-X2-10GER8D##	SM	DWDM Wavelength	80	0 to 5	-24 to 0.5	24

denotes DWDM 100GHz Spacing Wavelength Guide on page 86

TRANSCEIVERS

10 Gigabit Small Form Factor Pluggable **XFP**



- Dual Fiber Strands XFP Modules
- CWDM Dual Fiber Strands XFP Modules
- DWDM Dual Fiber Strands XFP Modules
- Single Fiber Strand XFP Modules



Features

- Hot-Pluggable XFP Footprint LC Optical Transceiver
- Digital Diagnostic Function
- Class 1 Laser International Safety Standard IEC-60825 Compliant
- Compatible with XFP Multi-Sourcing Agreement (MSA)
- XFP Optical Transceiver with duplex LC connector
- 10G small Form-Factor Pluggable(XFP) MSA compatible
- INF-8077i Digital Diagnostic Function(DMI)
- Maximum Link Length of 80km
- Single +3.3 V Power Supply
- Low Power Dissipation < 2W
- RoHS Compliant (all models)

Applications

- OC192/ STM64, 9.953Gbps
- 10G Ethernet, 10.312Gbps
- 10G Fiber Channel, 10.52Gbps
- OC192 with G.709 FEC, 10.709Gbps
- 10G Ethernet with G.709 FEC, 11.09Gbps

XFP is a standardized form factor for serial 10 Gb/s fiber optic transceivers. It is protocol-independent and fully compliant to the following standards: 10G Ethernet, 10G Fibre Channel, SONET OC-192, SDH STM-64 and OTN G.709, supporting bit rate from 9.956 through 11.36. XFP transceivers are used in datacom and telecom optical links and offer a smaller footprint and lower power consumption than other 10 Gb/s transponders.

Specifications

Standards	IEEE 802.3 2003
Dimensions	Width: 0.71" [18 mm] Depth: 3.07" [78 mm] Height: 0.33" [8 mm]
Power	3.3V
Power Consumption	0.66 Watts
Connector Type	LC
Environment	0°C – 70°C
Compliance	IEC-60825; FDA 21:CFR 1040.10 and 1040.11
Warranty	2 year

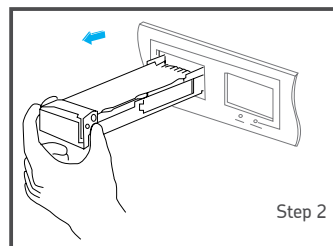
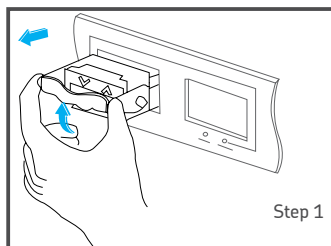

Step 1 : Pivot the XFP transceiver bail clasp up to release the XFP transceiver from the socket.

Step 2 : Slide the XFP transceiver out of the socket.

Ordering Information

Dual Fiber Strands XFP Modules

Data Rate	Part Number	Type	Wavelength	Distance	TX Power	RX Sens.	Fiber Budget
			nm	km	dBm	dBm	dB
	SV-XFP-SR	MM	850	0.3	-6 to -1	-10 to 0.5	1
	SV-XFP-ESR	MM	1300	2	-6 to -1	-15 to 0.5	6
	SV-XFP-LR1	SM	1310	10	-6 to -1	-15 to 0.5	9
9.95 Gb/s to	SV-XFP-LR2	SM	1310	20	-5 to 1	-15 to 0.5	10
11.1 Gb/s	SV-XFP-ER4	SM	1550	40	-1 to 4	-16.5 to 0.5	15.5
	SV-XFP-ZR8	SM	1550	80	0 to 5	-24 to -6	24
	SV-XFP-ZR10	SM	1550	100	1 to 5	-25 to -6	26

CWDM Dual Fiber Strands XFP Modules

Data Rate	Part Number	Type	Wavelength	Distance	TX Power	RX Sens.	Fiber Budget
			nm	km	dBm	dBm	dB
9.95 Gb/s	SV-XFP-10GER4C##	SM	1470 ~ 1610	40	-1 to 4	-16.5 to 0.5	15
to 11.1 Gb/s	SV-XFP-10GZR8C##	SM	1470 ~ 1610	80	0 to 5	-24 to -6	24

denotes wavelength range from 1270-1610nm.
 27 = 1270nm, 29=1290nm, 31=1310nm, 33=1330nm, 35=1350nm, 37=1370nm, 39=1390nm, 41=1410nm, 43=1430nm, 45=1450nm,
 47=1470nm, 49=1490nm, 51=1510nm, 53=1530nm, 55=1550nm, 57=1570nm, 59=1590nm, 61=1610nm

C-Band DWDM Dual Fiber Strands XFP Modules

100GHz Spacing Wavelength

Data Rate	Part Number	Type	Wavelength	Distance	TX Power	RX Sens.	Fiber Budget
			nm	km	dBm	dBm	dB
9.95 Gb/s	SV-XFP-10GER4D##	SM	DWDM Wavelength	40	0 to 4	-16.5 to 0.5	16.5
to 11.1 Gb/s	SV-XFP-10GER8D##	SM	DWDM Wavelength	80	0 to 5	-24 to -6	24

denotes DWDM 100GHz Spacing Wavelength Guide on page 86

50GHz Spacing Wavelength

Data Rate	Part Number	Type	Wavelength	Distance	TX Power	RX Sens.	Fiber Budget
			nm	km	dBm	dBm	dB
9.95 Gb/s	SV-XFP-10GER4AD##	SM	DWDM Wavelength	40	0 to 4	-16.5 to 0.5	16.5
to 11.1 Gb/s	SV-XFP-10GER8AD##	SM	DWDM Wavelength	80	0 to 5	-24 to -6	24
	SV-XFP-ZXD8ADT	SM	Tunable DWDM Wavelength	80	-1 to 3	-27 to -6	26

denotes DWDM 50GHz Spacing Wavelength Guide on page 87

Ordering Information

Single Fiber Strand XFP Modules

Data Rate	Part Number	Type	Wavelength	Distance	TX Power	RX Sens.	Fiber Budget
			nm	km	dBm	dBm	dB
	SV-XFP-LR11	SM	1270 TX 1310 RX	10	-5 to 0	-15 to 0.5	10
	SV-XFP-LR12	SM	1310 TX 1270 RX	10	-5 to 0	-15 to 0.5	10
	SV-XFP-LR21	SM	1270 TX 1310 RX	20	-5 to 0	-15 to 0.5	10
9.95 Gb/s to	SV-XFP-LR22	SM	1310 TX 1270 RX	20	-5 to 0	-15 to 0.5	10
11.1 Gb/s	SV-XFP-LR41	SM	1270 TX 1310 RX	40	0 to 5	-15 to 0.5	15
	SV-XFP-LR42	SM	1310 TX 1270 RX	40	0 to 5	-15 to 0.5	15
	SV-XFP-LR61	SM	1270 TX 1310 RX	60	0 to 5	-20 to -6	20
	SV-XFP-LR62	SM	1310 TX 1270 RX	60	0 to 5	-20 to -6	20
	SV-XFP-LR83	SM	1490 TX 1550 RX	80	0 to 5	-23 to -6	23
	SV-XFP-LR84	SM	1550 TX 1490 RX	80	0 to 5	-23 to -6	23

TRANSCEIVERS

Quad Small Form-factor Pluggable **QSFP**

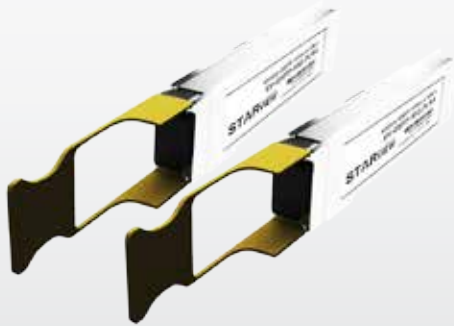

Dual Fiber Strands
QSFP Modules



AOC



QSFP28 Modules



QSFP Module

4 x 10Gbps Transmission

Quad Small Form Pluggable Plus (QSFP+) Transceiver Modules available with:

- Active Optical Cable with QSFP pre-terminated lengths
- Active Optical Cable with QSFP and SFP+ pre-terminated lengths
- MPO-8 Fiber QSFP Modules
- Dual Fiber Strands QSFP Modules

Supports applications such as:

- 40GBASE-SR4 (MPO-8)
- 40GBASE-ESR4 (MPO-8)
- 40GBASE-LR4L (MPO-8 or LC)
- 40GBASE-LR4 (MPO-8 or LC)
- 40GBASE-ER4 (LC)

Supports various wavelengths such as 850nm, 1310nm , CWDM and distances up to 30km

QSFP28

4 x 28Gbps transmission

Quad Small Form Pluggable 28Gbps (QSFP28) Transceiver Modules available with:

- Active Optical Cable with QSFP pre-terminated lengths
- MPO-8 Fiber QSFP Modules
- Dual Fiber Strands QSFP+ Modules

Supports applications such as:

- 100GBASE-SR4 (MPO-8)
- 100GBASE-LR4 (LC)
- 100GBASE-ER4 (LC)

Supports various wavelengths such as 850nm, 1310nm , CWDM and distances up to 25km

- Low power consumption
- Hot Pluggable module
- Hot Pluggable module
- Single MPO connector receptacle
- Built-in digital diagnostic functions
- Operating case temperature 0°C to +70°C
- 3.3V power supply voltage
- RoHS 6 compliant(lead free)

Specifications

Standards	IEEE 802.3 2003	
Dimensions QSFP	Width: 0.72" [18.35 mm]	Depth: 3.07" [78 mm] Height: 0.47" [12 mm]
Dimensions QSFP28	Width: 0.72" [18.35 mm]	Depth: 2.83" [72 mm] Height: 0.33" [12.4 mm]
Power	4.5V	
Power	QSFP	QSFP28
Consumption	<3.5 Watts	<4.5 Watts
Connector Type	MPO or LC	
Environment	0°C – 70°C	
Compliance	IEC-60825; FDA 21:CFR 1040.10 and 1040.11	
Warranty	2 year	

Ordering Information

AOC

Data Rate	Part Number	Type	Wavelength	Length	TX Power	RX Sens.	Fiber Budget
			nm	m	dBm	dBm	dB
40 Gb/s	SV-QSFP-40GT4T4-1M			1			
	SV-QSFP-40GT4T4-3M			3			
	SV-QSFP-40GT4T4-5M			5			
	SV-QSFP-40GT4T4-7M			7			
	SV-QSFP-40GT4T4-10M			10			
	SV-QSFP-40GT4T4-15M				15		
4x10.3125 Gb/s	SV-QSFP-40GT4T3-1M			1			
	SV-QSFP-40GT4T3-3M			3			
	SV-QSFP-40GT4T3-5M			5			
	SV-QSFP-40GT4T3-7M			7			
	SV-QSFP-40GT4T3-10M			10			
	SV-QSFP-100GT4T4-1M				1		
100 Gb/s	SV-QSFP-100GT4T4-3M			3			
	SV-QSFP-100GT4T4-5M			5			
	SV-QSFP-100GT4T4-7M			7			
	SV-QSFP-100GT4T4-10M				10		

Ordering Information

Dual Fiber Strands QSFP Modules

Data Rate	Part Number	Type	Wavelength	Distance	TX Power	RX Sens.	Fiber Budget
			nm	km	dBm	dBm	dB
	SV-QSFP-40G-PSR4	MM	850	0.15	-7.6 to 1	-9.5 to 2.4	1.9
	SV-QSFP-40G-PESR4	MM	850	0.4	-7.5 to 1	-9.9 to 2.4	2.4
	SV-QSFP-40G-SR2	MM	832	0.15	2.3 to -7.5	-9 to 2.3	1.5
	SV-QSFP-40G-PLR4L	SM	1310	1.4	-6 to 1.5	-11.5 to 2.3	5.5
40 Gb/s	SV-QSFP-40G-LR4L	SM	CWDM	2	-7.0 to 2.3	-11.5 to 2.3	4.5
	SV-QSFP-40G-PLR4	SM	1310	10	-6 to 1.5	-12.7 to 2.3	6.7
	SV-QSFP-40G-LR4	SM	CWDM	10	-7 to 2.3	-13.7 to 2.3	6.7
	SV-QSFP-40G-ER4	SM	CWDM	30	-3.7 to 4.5	-18.5 to -1.5	14.8

QSFP28 Modules

Data Rate	Part Number	Type	Wavelength	Distance	TX Power	RX Sens.	Fiber Budget
			nm	km	dBm	dBm	dB
	SV-QSFP-100G-PSR4	MM	850	0.10	-8.4 to 2.4	-30 to -9.2	18.6
	SV-QSFP-100G-LR4L	SM	CWDM	2	-0.5 to 2.5	-11.5 to 2.5	11
100 Gb/s	SV-QSFP-100G-LR4	SM	CWDM	10	-4.3 to 4.5	-10.6 to 4.5	6.3
	SV-QSFP-100G-LR4F	SM	CWDM FEC	10	-0.6 to 4	-6.9 to 4	6.3
	SV-QSFP-100G-ER4	SM	CWDM	25	-3.0 to 5.2	-15.8 to -4.0	12.8
	SV-QSFP-100G-ER4F	SM	CWDM FEC	25	-11.1 to 4.5	-13.9 to 4.9	12.8

TRANSCEIVERS

Compact Form Factor Pluggable **CFP**



CFP Module



CFP2 Module



CFP4 Module



CFP Module

Compact Form Factor Pluggable (CFP) Transceiver Modules available with:

- MPO-20 Fiber CFP Modules
- Dual Fiber Strands CFP Modules

Supports applications such as:

- 100GBASE-SR10 (MPO-20)
- 100GBASE-LR10 (MPO-20)
- 100GBASE-LR4 (LC)
- 100GBASE-ER4 (LC)
- 100GBASE-D4 (LC)

Supports various wavelengths such as 850nm, 1310nm, CWDM and DWDM with distances up to 40km

CFP2 Module

Compact Form Factor Pluggable generation 2 (CFP2) Transceiver Modules available with:

- MPO-8 Fiber CFP Modules
- Dual Fiber Strands CFP Modules

Supports applications such as:

- 100GBASE-SR4 (MPO-8)
- 100GBASE-LR4 (LC)

Supports various wavelengths such as 850nm and 1310nm, with distances up to 40km

CFP4 Module

Compact Form Factor Pluggable generation 4 (CFP4) Transceiver Modules available with:

Dual Fiber Strands CFP Modules

Supports applications such as Ethernet/ OTU4:

- 100GBASE-SR4 (MPO-8)
- 100GBASE-LR4 (LC)
- 100GBASE-ER4 (LC)

Supports various wavelengths such as 850nm and 1310nm, with distances up to 25km

Specifications

Standards	IEEE 802.3 2003		
Dimensions CFP	Width: 3.22" [82.0 mm]	Depth: 5.70" [144.8 mm]	Height: 0.53" [13.6 mm]
Dimensions CFP2	Width: 1.63" [41.5 mm]	Depth: 4.23" [107.5 mm]	Height: 0.58" [14.8 mm]
Dimensions CFP4	Width: 0.84" [21.5 mm]	Depth: 3.62" [92.0 mm]	Height: 0.54" [13.8 mm]
Power	3.3V		
Power	CFP	CFP2	CFP4
Consumption	<12.0 Watts	<9.0 Watts	<3.5 Watts
Connector Type	MPO or LC		
Environment	0°C – 70°C		
Compliance	IEC-60825; FDA 21:CFR 1040.10 and 1040.11		
Warranty	2 year		

Ordering Information

Dual Fiber Strands CFP Modules

Data Rate	Part Number	Type	Wavelength	Distance	TX Power	RX Sens.	Fiber Budget
			nm	km	dBm	dBm	dB
40 Gb/s	SV-CFP-40G-LR4	SM	CWDM	10	-7 to 2.3	-13.7 to 2.3	6.7
	SV-CFP-100G-PSR10	MM	850	0.15	-5.6 to -30	-9.5 to 3	3.9
100 Gb/s	SV-CFP-100G-LR4	SM	CWDM	10	-4.3 to -30	-10.6 to 4.5	6.3
	SV-CFP-100G-ER4	SM	CWDM	40	-2.7 to 2.9	-20.9 to 4.5	18.2
	SV-CFP-100G-D4	SM	Tunable DWDM Wavelength	40	-2.5 to 2.5	-10 to 2	7.5
120 Gb/s	SV-CXP-120G-PSR12	MM	850	0.1	-5.6 to -30	-9.5 to 3	3.9

Dual Fiber Strands CFP2 Modules

Data Rate	Part Number	Type	Wavelength	Distance	TX Power	RX Sens.	Fiber Budget
			nm	km	dBm	dBm	dB
100Gb/s	SV-CFP2-100G-LR4	SM	CWDM	10	-4.3 to 4.5	-10.6 to 4.5	6.3
	SV-CFP2-100G-LR4F	SM	CWDM	10	-2.5 to 2.9	-6.9 to 4	4.4

Dual Fiber Strands CFP4 Modules

Data Rate	Part Number	Type	Wavelength	Distance	TX Power	RX Sens.	Fiber Budget
			nm	km	dBm	dBm	dB
	SV-CFP4-100G-PSR4	MM	CWDM	0.1	-6.4 to 3.0	-10.3 to 2.4	3.9
	SV-CFP4-100G-LR4	SM	CWDM	10	-4.3 to 4.5	-10.6 to 4.5	6.3
100Gb/s	SV-CFP4-100G-LR4F	SM	CWDM	10	-0.6 to 4	-6.9 to 4	6.3
	SV-CFP4-100G-ER4	SM	CWDM	25	-1.9 to 4.5	-14.7 to -4.9	12.8
	SV-CFP4-100G-ER4F	SM	CWDM	25	-1.1 to 4.5	-13.9 to -4.9	12.8

STARPOD

STARPOD

Starview Programmable Optical Device



- STARVIEW Programmable Optical Device (STARPOD) for SFP/ SFP+ and XFP modules
- Field Programmable Device for all Starview Transceivers SFP/ SFP+ and XFP modules
- Support various vendors' coding from database
- Requires access to the internet/ cloud in order to do reprogramming of the transceiver modules
- Coding is based on per license key per module
- Programming period is less than 1 minute per module
- Read and debug original coding
- Patent in progress

STARPOD

Starview Programmable Optical Device



-Programming Kit
-For Starview SFP/SFP+/XFP



Features

- Programming Kit for Starview SFP/SFP+/XFP
- User friendly graphical user interface(GUI)
- USB port for basic set up
- Multi-vendor programming
- Support 3rd party modules if they are not password protected.
- Requires internet connection during operation
- 1 license key for each module
- License key is offered separately
- Wavelength tuning for DWDM tunable SFP+ module

Starview Programmable Optical Device (STARPOD) is designed to allow the user to re-program Starview transceiver modules (typically SFP/ SFP+ and XFP) in the field. The STARPOD is also capable to tune the DWDM wavelengths of the DWDM tunable SFP+ module. This flexibility to re-program the transceiver module allows the user to connect the module to interwork with multiple leading vendors. The user will save time and money to support the wide varieties of networking equipment today.

Using STARPOD with a computer, the user logs into the internet and re-program the transceiver module with a license key obtainable from Starview certified partner. The re-programming takes less than a minute for each transceiver module. After re-programming, the transceiver module can work with the leading vendor of choice. The module can be re-programmed as many times, as long as the license key is validated.



STARPOD-Purchase VS. Transceiver-Purchase

Using the STARPOD, even for only a few transceivers, soon covers its cost. Or you can get preconfigured transceivers from our Distribution Partners. You decide which solution fits your needs best.



One time Cost: Purchase price for the STARPOD
Running costs: license
Suitable from: ...a need of > 50 transceivers per year
Suited for: ...Network Operators, System House, Resellers

One time Cost: Purchase price for the transceivers
Running costs: None
Suitable from: ...1 transceivers
Suited for: ...Network Operators, Resellers

STARPOD - Transceiver Database and more....

- CISCO
- Juniper
- Alcatel Lucent
- Extreme Networks
- Force 10
- Huawei
- HP
- H3C
- Arista Networks
- Transition Networks
- ADVA Optical Networking
- BTI
- Intel
- EXFO
- JDSU
- Allied Telesis
- Tellabs
- Nortel
- ALAXLA Networks
- Netscout
- Adtran
- Brocade
- Ericsson
- RAD
- Avaya
- NSN
- VSS Monitoring
- Gigamon
- Cyan
- Hitachi Metals
- Etc.

Specifications

Modules	SFP,SFP+,XFP
Data Rate/Wavelength/Distance	As per SFP/SFP+/XFP data rate is not affected during programming
Dimension	Width: 4.09" [104 mm] Depth: 4.21" [107 mm] Height: 1.18" [30 mm]
AC Adapter Power Input	100 - 240VAC
AC Adapter Power Output	3.3VDC 7.2W max
AC Adapter Current Output	2.19Amp
Operating System	Microsoft Windows 7, Microsoft Windows 8
Warranty	2 Years

Download this software from our webpage at www.starviewint.com. With the ease and flexibility of connecting the STARPOD to your computer.



STARPOD is now capable to tune the DWDM wavelengths of our SFP+ modules.

you can tune the SFP+ to your desired DWDM wavelengths without relying on the network equipment in operation. Talk to Starview for more information of the product.



Wavelengths supported

The following table provides correlation of the ITU-frequency DWDM channel number, wavelength and frequency

## ITU Channel	Wavelength	Frequency (THz)	## ITU Channel	Wavelength	Frequency (THz)	## ITU Channel	Wavelength	Frequency (THz)
11.5	1568.36	191.15	28	1554.94	192.80	44.5	1541.75	194.45
12	1567.95	191.20	28.5	1554.54	192.85	45	1541.35	194.50
12.5	1567.54	191.25	29	1554.13	192.90	45.5	1540.95	194.55
13	1567.13	191.30	29.5	1553.73	192.95	46	1540.56	194.60
13.5	1566.72	191.35	30	1553.33	193.0	46.5	1540.16	194.65
14	1566.31	191.40	30.5	1552.93	193.05	47	1539.77	194.70
14.5	1565.90	191.45	31	1552.52	193.10	47.5	1539.37	194.75
15	1565.50	191.50	31.5	1552.12	193.15	48	1538.98	194.80
15.5	1565.09	191.55	32	1551.72	193.20	48.5	1538.58	194.85
16	1564.68	191.60	32.5	1551.32	193.25	49	1538.19	194.90
16.5	1564.27	191.65	33	1550.92	193.30	49.5	1537.79	194.95
17	1563.86	191.70	33.5	1550.52	193.35	50	1537.40	195.0
17.5	1563.45	191.75	34	1550.12	193.40	50.5	1537.00	195.05
18	1563.05	191.80	34.5	1549.72	193.45	51	1536.61	195.10
18.5	1562.64	191.85	35	1549.32	193.50	51.5	1536.22	195.15
19	1562.23	191.90	35.5	1548.91	193.55	52	1535.82	195.20
19.5	1561.83	191.95	36	1548.51	193.60	52.5	1535.43	195.25
20	1561.42	192.0	36.5	1548.11	193.65	53	1535.04	195.30
20.5	1561.01	192.05	37	1547.72	193.70	53.5	1534.64	195.35
21	1560.61	192.10	37.5	1547.32	193.75	54	1534.25	195.40
21.5	1560.20	192.15	38	1546.92	193.80	54.5	1533.86	195.45
22	1559.79	192.20	38.5	1546.52	193.85	55	1533.47	195.50
22.5	1559.39	192.25	39	1546.12	193.90	55.5	1533.07	195.55
23	1558.98	192.30	39.5	1545.72	193.95	56	1532.68	195.60
23.5	1558.58	192.35	40	1545.32	194.0	56.5	1532.29	195.65
24	1558.17	192.40	40.5	1544.92	194.05	57	1531.90	195.70
24.5	1557.77	192.45	41	1544.53	194.10	57.5	1531.51	195.75
25	1557.36	192.50	41.5	1544.13	194.15	58	1531.12	195.80
25.5	1556.96	192.55	42	1543.73	194.20	58.5	1530.72	195.85
26	1556.55	192.60	42.5	1543.33	194.25	59	1530.33	195.90
26.5	1556.15	192.65	43	1542.94	194.30	59.5	1529.94	195.95
27	1555.75	192.70	43.5	1542.54	194.35	60	1529.55	196.0
27.5	1555.34	192.75	44	1542.14	194.40	60.5	1529.16	196.05

Ordering Information

SV-STARPOD-USB	Starview Programmable Optical Device (STARPod) for reprogramming Starview Transceiver modules (SFP/ SFP+/ XFP) to support various manufacturer's coding, c/w USB cable and AC/DC power adapter
SV-STARPOD-LIC	Starview Programmable Optical Device (STARPod) per license key to reprogram Starview Transceiver module (SFP/ SFP+/ XFP)

STARMUX

STARMUX

Starview CWDM Mux/Demux

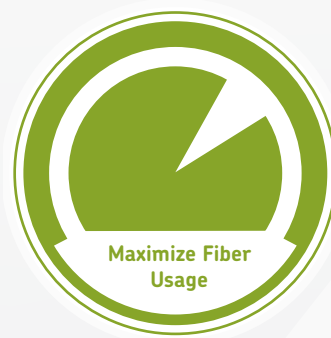

- Cost Effective
- Duplex/ Simplex WAN Fiber connection
- Metallic casing and connectors
- Passive Equipment suitable for outdoor enclosure
- Compact Enclosure
- Low insertion loss
- Maximize Fiber Usage
- Maximum 9 CH CWDM for Rack Mount Enclosure Module
- Maximum 18 CH CWDM for 19" Rack Mount able unit

What is WDM?

- Wavelength Division Multiplexing
- Technique where optical signals with different wavelengths are combined, transmitted together, and separated again. It is mostly used for optical fiber communications to transmit data in several (or even many) channels with slightly different wavelengths
- Widely used to increase capacity on routes with fiber exhaustion
- Inexpensive alternative to installing more fiber or leasing additional fibers



CWDM Mux/ Demux and OADM

CWDM	Mux / Demux	OADM
Abbreviations	Multiplexing and Demultiplexing	Optical Add and Drop Multiplexing
Components	Consists of Optical combiner and splitters	Consists of Optical circulators, combiners and splitters
Topology	Point to Point	Linear Add and Drop
Insertion loss	3.5dB per channel	1.7dB per channel

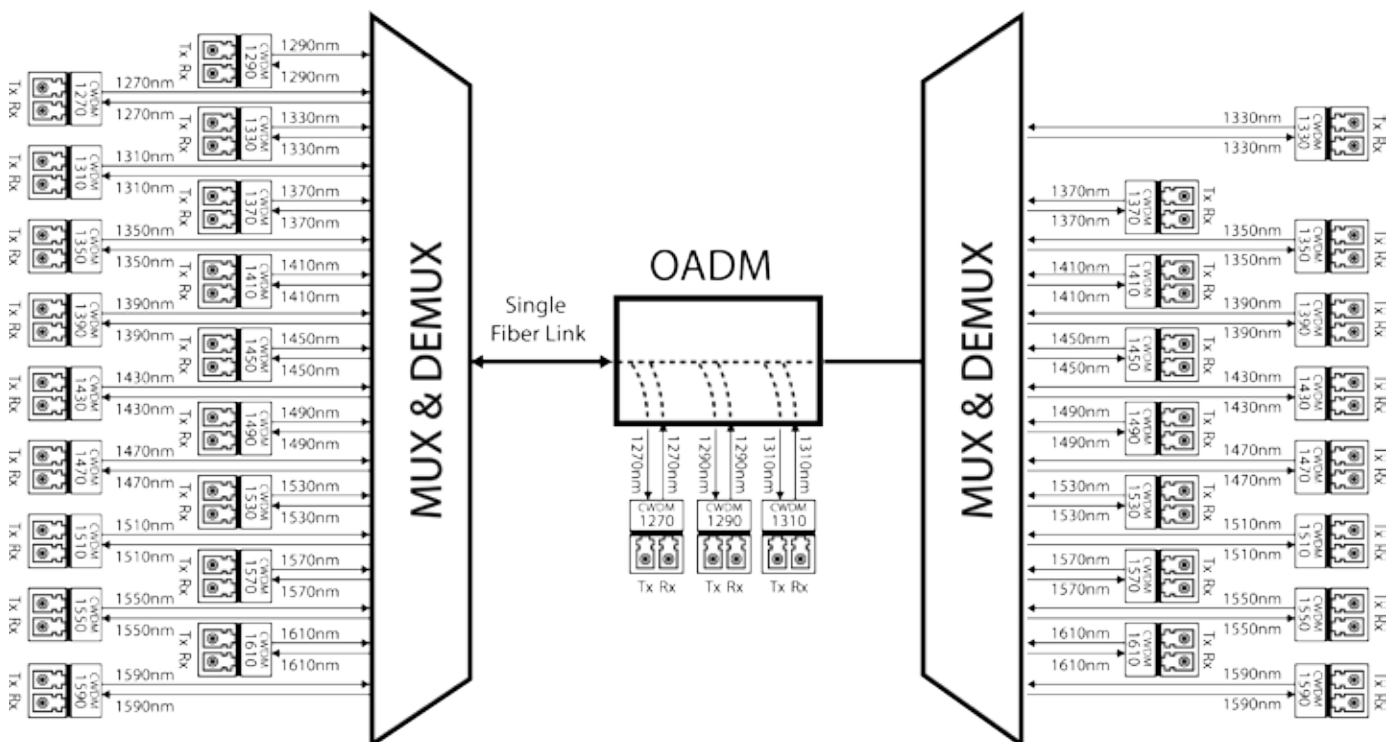

STARMUX

Starview CWDM Mux/Demux



STARMUX Indoor



Starview Mux/Demux Module



Starview Rack Mount Chassis

Features

- Increase bandwidth on existing fiber infrastructure
- Alleviate fiber exhaustion
- Transmit multiple protocols over an existing duplex fiber link by combining the fiber outputs of multiple media converters
- "Plug and play," no configuration of CWDM components
- Provide scalable bandwidth of up to 10Gbps per channel over existing fiber links
- Use existing standard optical ports on switches and routers

Applications

- Line Monitoring
- WDM Network
- Fiber Optical amplifiers

STARMUX is a passive technology that allows for any protocol to be transported over the link, as long as it is at a specific wavelength (i.e. T1 over fiber at 1570nm transported alongside 10Gbps Ethernet at 1590nm). Because the multiplexers simply refract light at any network speed, regardless of the protocol being deployed, STARMUX can help to future proof the networking infrastructure.

Specifications

Parameters	4 Channel	5 Channel	8 / 9 Channel	16 / 18 Channel
Operating Wavelength	1500nm - 1620nm	1500nm - 1620nm	1270nm - 1610nm	1270nm -1610nm
Center Wavelength (λ_c)	1510nm - 1610nm	1510nm - 1610nm		
Max Insertion Loss	1.7 dB/channel	2.0 dB/channel	2.5 dB	3.5 dB
Channel Uniformity			1.0 dB	1.5 dB
Channel Ripple			0.3 dB	0.3 dB
Isolation Adjacent			>30 dB (Demux)	>30 dB (Demux)
Isolation Non-adjacent			>40 dB(Demux)	>40 dB (Demux)
Insertion Loss Temp. Sensitivity			<0.005 dB/°C	
Wavelength Temp. Shifting			<0.002 nm/°C	
Polarization Dependent Loss			<0.1 dB	
Polarization Mode Dispersion			<0.1 PS	
Directivity			>50 dB	
Return Loss			>45 dB	
Maximum Power Handling			500 mW	
Operating Temperature			-5°C to 75°C	
Storage Temperature			-40°C to 85°C	
Package	19" case packaging 440mm x 330mm x 200mm			

Applications – CWDM with dual fiber connection

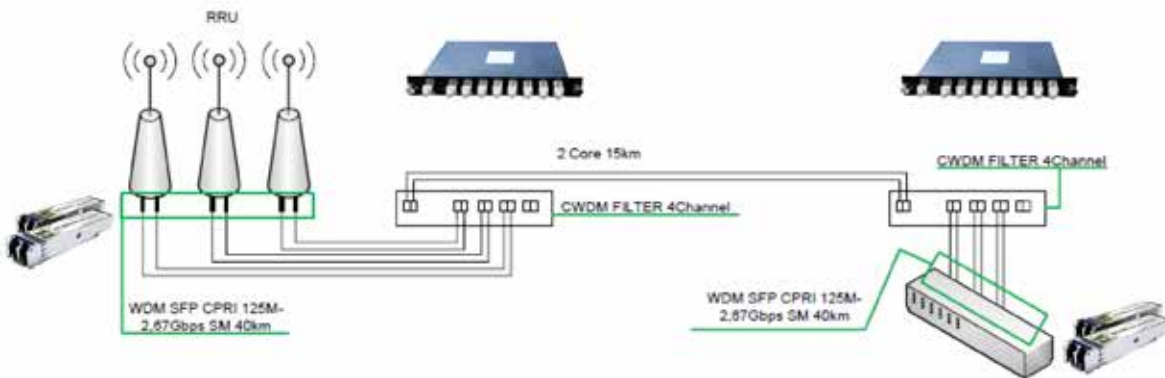

Applications – CWDM with single fiber connection

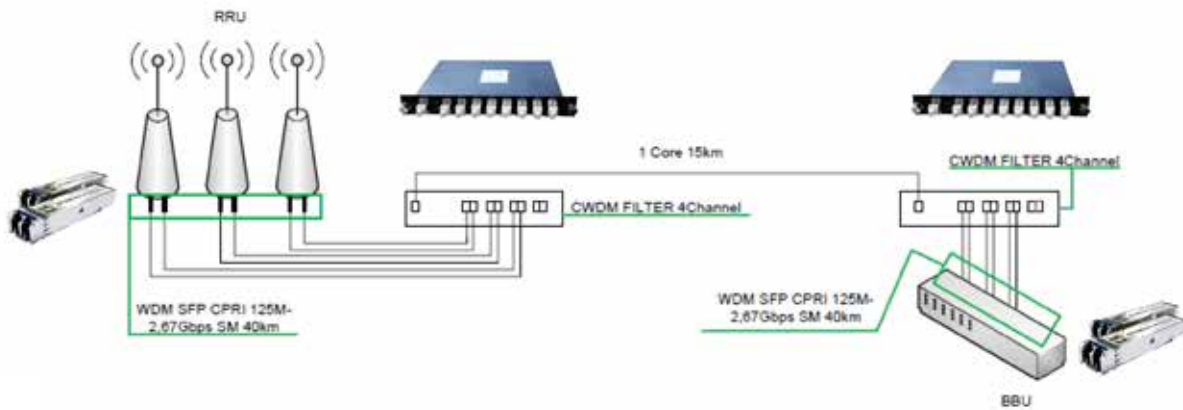

Ordering Information

Accessory:

SVR-STARMUX-19R

Starview 19" 2-slot for STARMUX Rack Mount Enclosures

Manufacturer: Starview International

Type: CWDM MUX/DEMUX Rack Mount

Channel Configuration:
 451: 4 Ch. 1510/1530/1550/1570nm
 453: 4 Ch. 1530/1550/1570/1590nm
 455: 4 Ch. 1550/1570/1590/1610nm
 551: 5 Ch. 1510/1530/1550/1570nm+1310nm
 553: 5 Ch. 1530/1550/1570/1590nm+1310nm
 555: 5 Ch. 1550/1570/1590/1610nm+1310nm
 847: 8 Ch. 1470 - 1610nm
 947: 9 Ch. 1470 - 1610nm+1310nm
 1627: 16 Ch. 1270 - 1610nm
 -1430nm-1450nm
 1827: 18 Ch. 1270 - 1610nm

Fiber Type: S: Simplex Type D: Duplex Type

Connectors: LC: LC/PC SC: SC/PC

SVR - STARMUX -

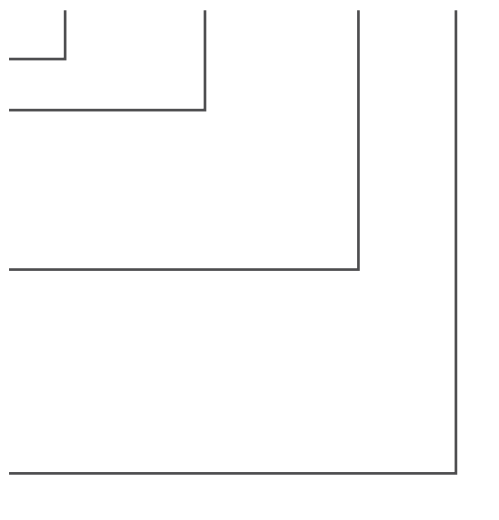

Example:

SVR-STARMUX-1627-DLC

Starview CWDM 16 Channel MUX/DEMUX 19" Rack Mountable Module 1270/ 1290/ 1310/ 1330/ 1350/ 1370/ 1390/ 1410/ 1470/ 1490/1510/ 1530/ 1550/ 1570/ 1590/ 1610nm with 1 x Duplex LC COM port

STARMUX

CWDM OADM



Features

- Increase bandwidth on existing fiber infrastructure
- Alleviate fiber exhaustion
- Transmit multiple protocols over an existing duplex fiber link by combining the fiber outputs of multiple media converters
- "Plug and play," no configuration of CWDM components
- Provide scalable bandwidth of up to 10Gbps per channel over existing fiber links
- Use existing standard optical ports on switches and routers

Applications

- Line Monitoring
- WDM Network
- Fiber Optical amplifier

CWDM OADM STARMUX is a passive technology that allows for any protocol to be transported over the link, as long as it is at a specific wavelength (i.e. T1 over fiber at 1570nm transported alongside 10Gbps Ethernet at 1590nm). Because the multiplexers simply refract light at any network speed, regardless of the protocol being deployed, STARMUX can help to future proof the networking infrastructure.

Specifications

Parameters	4 Channel	5 Channel	8 / 9 Channel	16 / 18 Channel
Operating Wavelength	1500nm - 1620nm		1460nm - 1620nm	
Center Wavelength (λ_c)	1510nm - 1610nm		1470nm - 1610nm	
Add/Drop Ch. Max Insertion Loss	0.7 dB		0.7 dB	
Pass Ch. Max Insertion Loss	1.0 dB		1.0 dB	
Insertion Loss Temp. Sensitivity		<0.005 dB/°C		
Wavelength Temp. Shifting		<0.002 nm/°C		
Polarization Dependent Loss		<0.1 dB		
Polarization Mode Dispersion		<0.1 PS		
Directivity		>50 dB		
Return Loss		>45 dB		
Maximum Power Handling		500 mW		
Operating Temperature		-5°C to 75°C		
Storage Temperature		-40°C to 85°C		

Applications – CWDM with OADM fiber connection

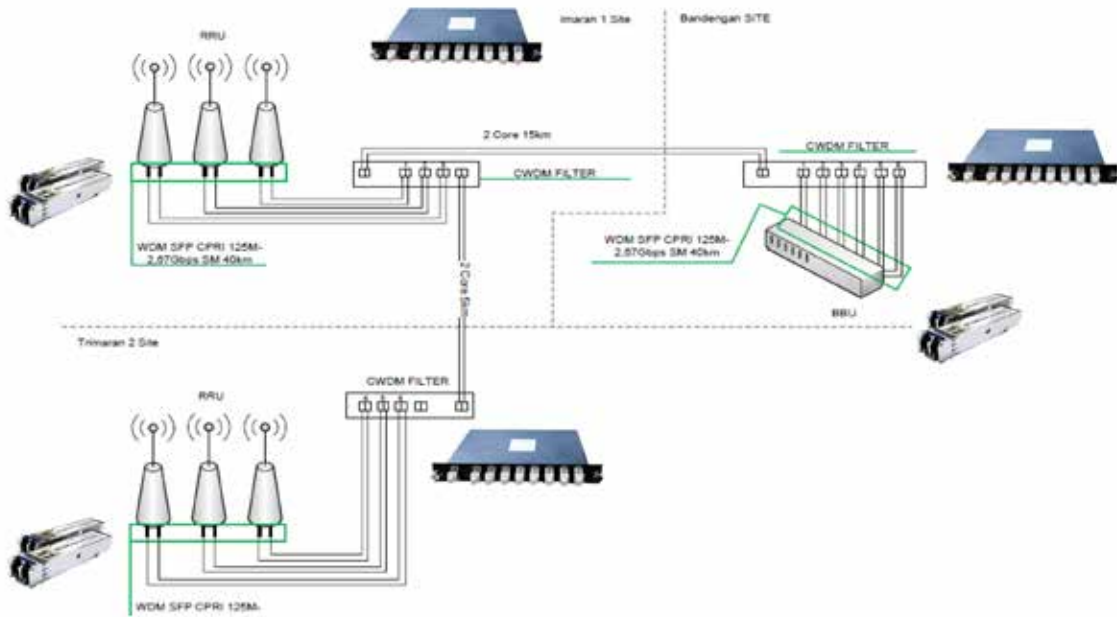

Ordering Information

Accessory:

SVR-STARMUX-19R

Starview 19" 2-slot for STARMUX Rack Mount Enclosures

Manufacturer: Starview International

Type: Coarse Wavelength Division Multiplexing

Channel Configuration: 3: 3 Ch. 4: 4 Ch.

Client Ports

31:	1310 port	31:	Add/Drop 1310 port
33:	1330 port	33:	Add/Drop 1330 port
35:	1350 port	35:	Add/Drop 1350 port
37:	1370 port	37:	Add/Drop 1370 port
41:	1410 port	41:	Add/Drop 1410 port
43:	1430 port	43:	Add/Drop 1430 port
45:	1450 port	45:	Add/Drop 1450 port
47:	1470 port	47:	Add/Drop 1470 port
49:	1490 port	49:	Add/Drop 1490 port
51:	1510 port	51:	Add/Drop 1510 port
53:	1530 port	53:	Add/Drop 1530 port
55:	1550 port	55:	Add/Drop 1550 port
57:	1570 port	57:	Add/Drop 1570 port
59:	1590 port	59:	Add/Drop 1590 port
61:	1610 port	61:	Add/Drop 1610 port

Line Port: S: Simplex Type D: Duplex Type

Connectors: LC: LC/PC SC: SC/PC

Example:

SVR-STARMUX-3AD3149-SLC

Starview CWDM 3 Channel Optical Add and Drop MUX/DEMUX Rack Mount Enclosure Module 1310/ 1470/ 1490nm with 2 x Simplex LC COM ports

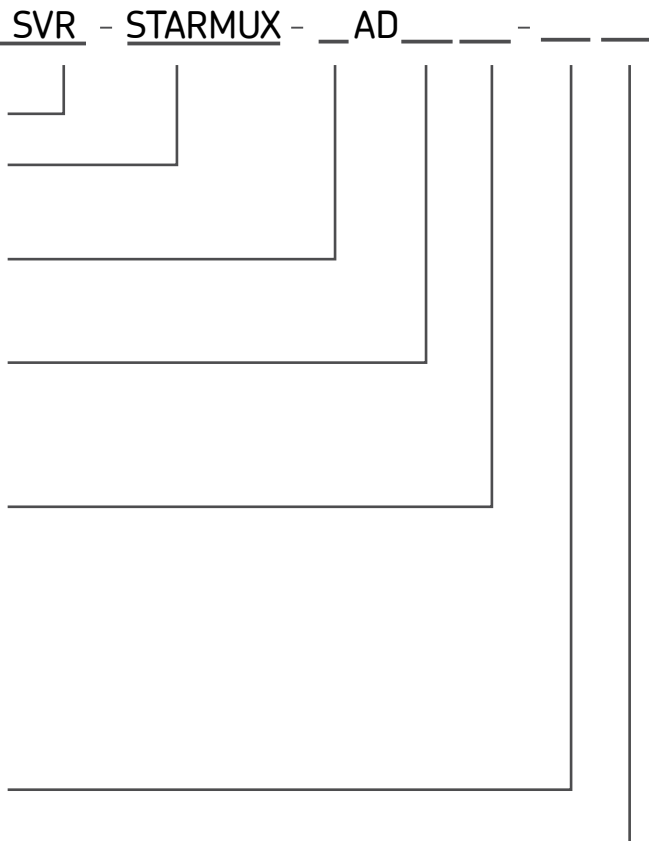

STARMUX

Starview CWDM Mux/Demux Outdoor Distribution Box



STARMUX Outdoor

Features

- Easy installation and maintenance
- Wall and pole mountable
- IP65 enclosure suitable for outdoor use
- Increase bandwidth on existing fiber infrastructure
- Alleviate fiber exhaustion
- Transmit multiple protocols over an existing fiber link (Simplex or Duplex)
- Provide scalable bandwidth of up to 10Gbps per channel
- Plug and Play, no configuration of CWDM components

Applications

- Telecommunication Networks
- Cross connect or inter-connect
- Telecom: FTTx, Mobile network and transmission

Starview STARMUX Coarse Wavelength Division Multiplexing (CWDM) Outdoor Distribution Box (ODB) consists of Starview CWDM Mux/ Demux module with metallic LC/UPC connectors enclosed in a PC/ ABS enclosure. STARMUX CWDM uses passive technology that allows any protocol to be transported over the fiber link, as long as it is at a specific CWDM wavelength. The STARMUX provides a simple and affordable method to maximize existing fiber capacity with little or no increased cost.

Specifications

Physical Dimension	250mm x 190mm x 72mm
Installation Dimension	130mm x 82mm
Weight	2kg
Colour	White
Operating Temperature	-40°C to 85°C
Operating Humidity	10% to 95% (non-condensing)

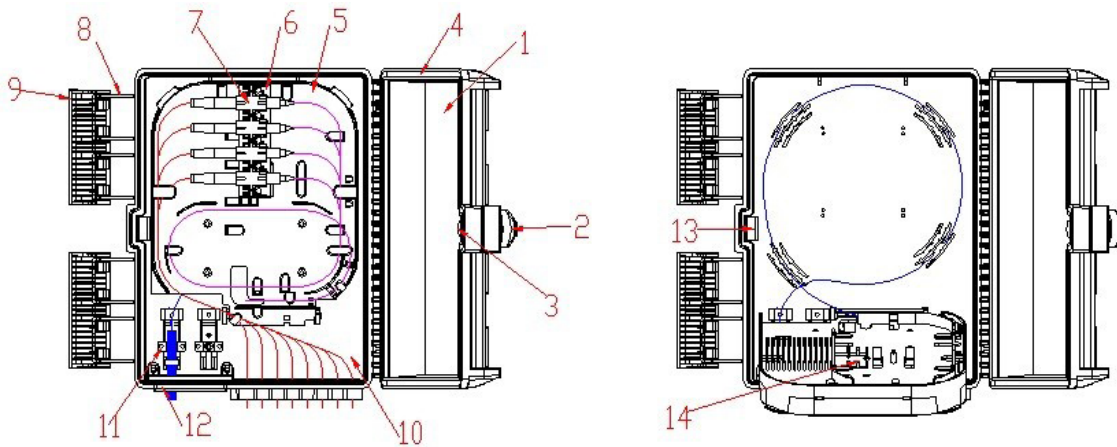

No.	Description
1	Front Cover
2	Lock Cover
3	Lock
4	Seal
5	Fiber Flap
6	Fiber Adaptor
7	Fiber Coupler

No.	Description
8	Front Cover lever
9	Front Cover clip
10	Fiber Outlet
11	Fiber cable holder
12	Fiber Inlet
13	Front cover lock mechanism
14	Fiber distribution guide

Ordering Information

Manufacturer: Starview International

Type: Coarse Wavelength Division Multiplexing
Outdoor Distribution Box

Channel Configuration: 4: 4 Ch. 8: 8 Ch. 9: 9 Ch.
16: 16 Ch. 18: 18 Ch.

Client Ports: 427: 4 Ch. 1270 - 1330nm
827: 8 Ch. 1270 - 1410nm
947: 9 Ch. 1470 - 1610nm+1310nm
1627: 16 Ch. 1270 - 1610nm
-1430nm-1450nm
1827: 18 Ch. 1270 - 1610nm

Line Port: S: Simplex Type D: Duplex Type

Connectors: LC: LC/PC SC: SC/PC

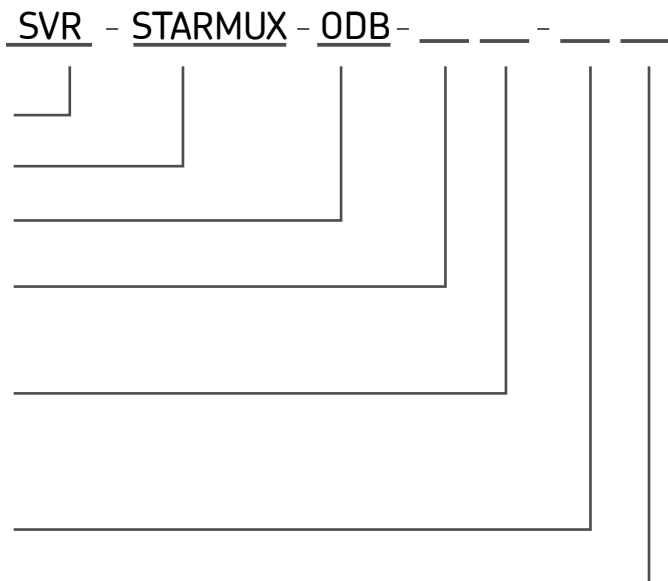

Example:

SVR-STARMUX-ODB-427-DLC

Starview CWDM 4 Channel MUX/DEMUX Outdoor Distribution Box (ODB) 1270/ 1290/ 1310/ 1330nm with 1 x Duplex LC COM ports

STARTAP

STARTAP

Starview Optical Network TAP

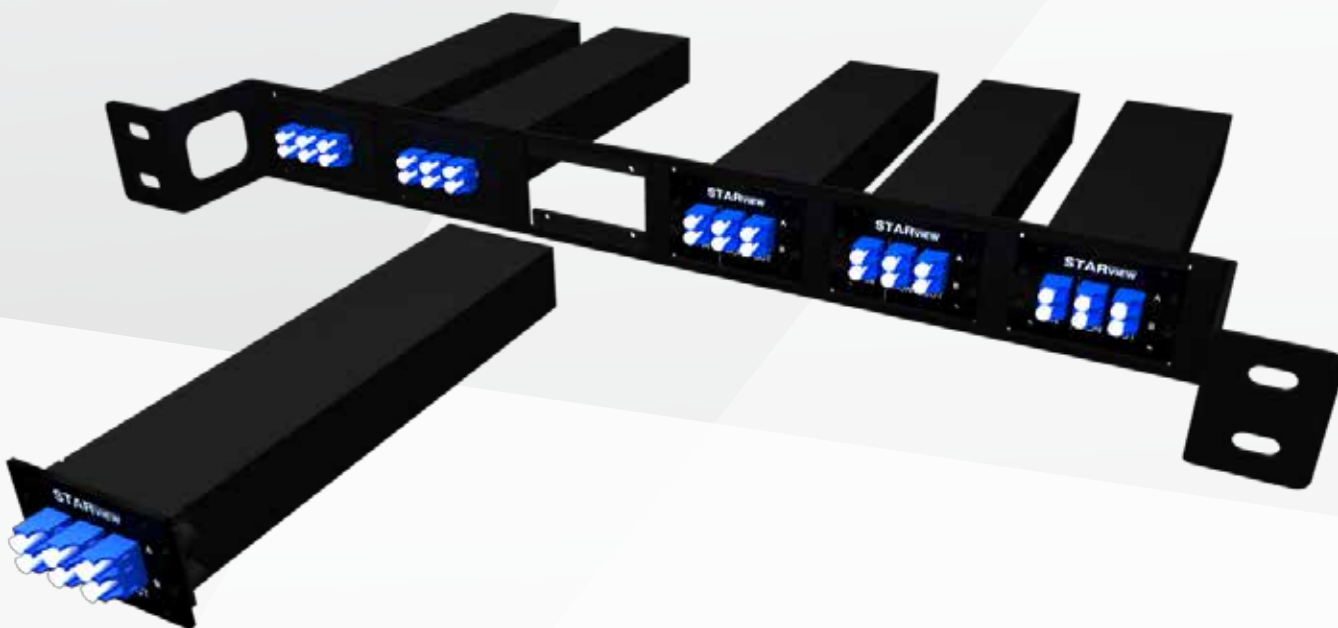

- Cost Effective
- Passive Equipment
- Compact Enclosure
- Low insertion loss
- User defined configuration for different split ratio and fiber optic types (SM / MM)
- Flexible and Modular design with front access
- Industry standard color coding for fiber optic connectors

What is Network Tap?

- Hardware device to provide a way to access the data flowing across a fiber optic network
- Consists of (at least) 3 ports: Port A from Equipment A TX port, Port B to Equipment B RX port, and a Monitoring Port
- In-line device to connect between 2 Transmission Network Equipment
- Protocol and Data rate transparent
- Available in Singlemode or Multimode taps

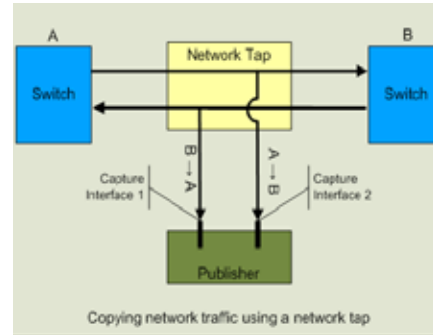

Types of Network Taps

Singlemode (SM)	Multimode (MM)
9/125um fiber optic splitter	50/125um or 60/125um fiber optic splitter
Supports CWDM, DWDM, 1310 or 1550nm SM wavelengths	Supports 850 or 1300nm MM wavelengths
Split Ratios available in 10/90, 20/80, 30/70, 40/60 or 50/50	
Passive component	
Insertion loss due to in line connection	

- STARview optical network TAP (STARTAP)
- Passive Optical Network Tap
- Support multiple network protocols, including high speed voice, video and data communications for networking, storage and wireless applications
- Ideal for applications such as:
 - Intrusion Detection System
 - Application Performance Monitoring
 - Packet Capture
 - Data Forensic

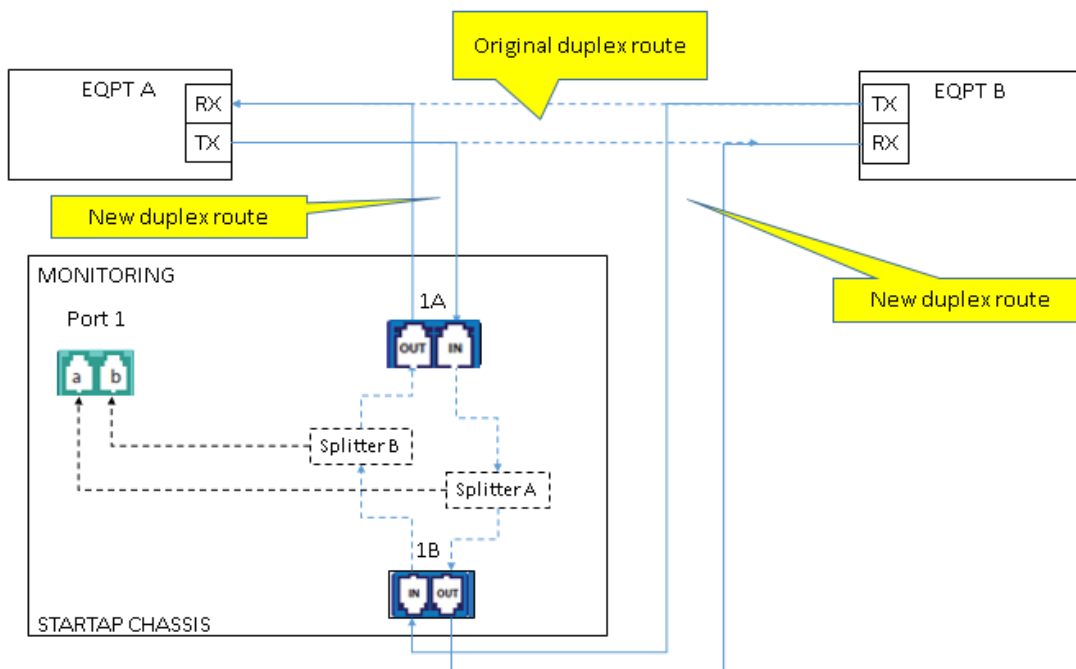

STARTAP

Starview Optical Network TAP



STARTAP Module + Rack Mount Chassis

Business Challenges

- Meet requirements for CALEA, create CDRs for billing, and provide service quality information to customers
- Proliferation of monitoring tools, with many tools needing access to the same network traffic.
- At ODF, there is only one monitoring port per link.
- ODF does not monitor the links' status at the monitoring ports. Operational team does not have visibility of the monitoring port link status should there be any failure. Link failure not make known instantaneously to the team.

Single Link STARTAP Module

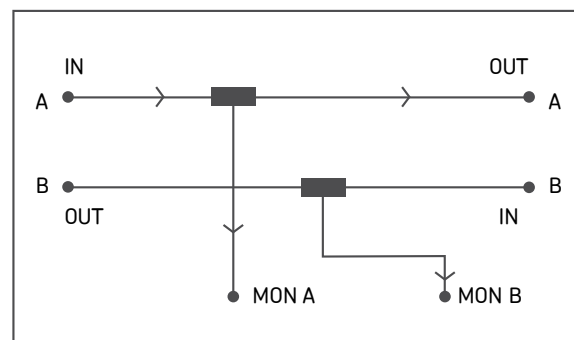
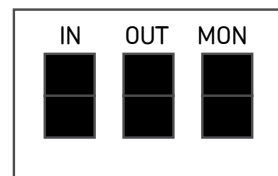

- Compact modular modules
- Each module consists of 1 link of LC/UPC connectors for tapping, i.e. 2 x IN, 2 x OUT, 2 x MON
- Customized with singlemode or multimode splitter
- Option 1RU Rack Mount Chassis for up to 6 x modules

STARTAP is a modular Starview Optical Tap that allows customers to create duplicate links on the optical fiber for monitoring purposes. **STARTAP** can be configured according to customer's split ratio, fiber optic types (SM / MM) and connectors. The key advantage is it's modular design where customers can install a 1U rack capable of inserting up to 6 **STARTAP** modules. The modules are front accessible with connectors and locking screws. The module can be inserted and removed from the front, and can be modified in later stage for different splitter applications. The design also allows 2 **STARTAP** to be placed back to back if the cabinet is both front and back access. The **STARTAP** has been designed specifically with the customer's application, space constraint and accessibility in mind.

Ordering Information

Chassis:

SV-STARTAP-19C

Starview 19" 1U height **STARTAP** chassis with 6 slots for **STARTAP** modules, c/w 6 blank panels and clasp panel for easy clip-on to **STARTAP** chassis to allow fiber management, c/w (6) six blank panels for **STARTAP** chassis with 4 thumbscrews, and (1) one clasp panel for easy clip-on to **STARTAP** chassis to allow fiber management

Accessory:

SV-STARTAP-BLANK

Blank panel for **STARTAP** chassis c/w 4 thumbscrews

SV-STARTAP-CLASP

Clasp panel for easy clip-on to **STARTAP** chassis to allow fiber management

STARTAP Modules:

Manufacturer: Starview International

Type: Optical Fiber Tap

Splitter: 102: 1 x 2 **STARTAP**
104: 1 x 2 **STARTAP**
204: 2 x 4 **STARTAP**

Input Value: 10: 10%
20: 20%
30: 30%
.....
80: 80%
90: 90%

Ferrule: _ : Singlemode
M : Multimode

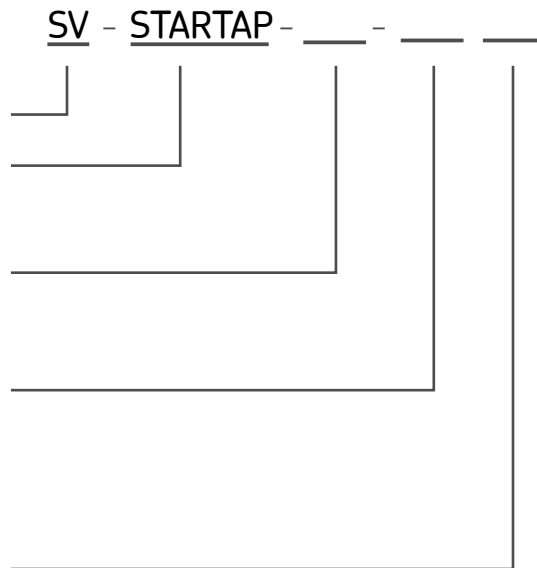

Example:

SV-STARTAP-102-30

Starview 1 x 2 **STARTAP** 9/125um singlemode splitter with 1 x Input port (LC/ UPC) and 1 x 30% MON port (LC/ UPC) and 1 x 70% output ports (LC/ UPC)

High Density STARTAP

Starview STARTAP modular-24 splitters with Chassis



Features

- Standard size, light weight and reasonable structure
- Front access for easy cable management
- Compact design for space saving
- Front mark on the plate is easy for identification and operation
- Easy for management and operation
- Supports Multimode and Singlemode fiber splitting
- Wide Operating Temperature from -40°C to 85°C
- High Reliability and Stability

Applications

- Transition from Backbone cabling to distribution switching
- Interconnect to active equipment in server cabinet
- Cross connect or inter-connect

Applications

- Telcordia GR-1209-CORE
- Telcordia GR-1221-CORE
- RoHS

Specifications

Parameters		Singlemode	Multimode
Operating Wavelength		1260nm ~ 1620nm	850nm, 1300nm
	50/50	≤ 3.60 dB	≤ 4.20 dB
	30/70	≤ 6.00/ 1.90 dB	≤ 6.30/ 2.40 dB
Insertion Loss	20/80	≤ 7.90/ 1.20 dB	≤ 8.10/ 1.70 dB
	10/90	≤ 11.30/ 0.65 dB	≤ 11.60/ 1.20 dB
Directivity		≤ 50 dB	≤ 40 dB
Operating Temperature		-40°C to +85°C	-20°C to +70°C
Colour		Black	
Chassis Dimension		44mm x 482mm x 240mm 1RU	
Chassis Weight		2.8kg	
Module Dimension		189mm x 40mm x 13mm	
Module Weight		0.1kg	

Note: The splitter configuration can be tailored with the input ports, monitoring ports and output ports according to customer's requirement.



Starview STARTAP modular-24 splitters with chassis, comes with 24 modules of 6 x LC/UPC connectors each, enclosed in a 19" 1RU chassis. Each module is capable to equip 2 x 1:2 splitter ports, making it the most compact 1RU chassis to house up to 48 splitters altogether. Each Planar Lightwave Circuit (PLC) splitter performs optical power management fabricated using silica optical waveguide technology. It features small size, high reliability, wide operating wavelength range and good channel-to-channel uniformity, and is widely used in PON networks to realize optical signal power splitting. Starview provides a whole series of 1xN splitter products that are tailored for specific applications. All products meet GR-1209-CORE and GR-1221-CORE requirements.

19" Rack Mount Enclosure, 1RU for up to 24 x STARTAP modules. Individual rack mount fiber modules organize, manage and protect fiber optic splitters. The enclosure is constructed of steel material and the front access is designed to easily remove for cabling and connector installation.

Ordering Information

Chassis:

SV-STARTAP-19C-V2

Starview 19" High Density 24 slots, 1U height STARTAP chassis. Allows upto 24 High Density STARTAP modules to be installed in a standard 19" rack

STARTAP High Density Modules:

Manufacturer: Starview International

Type: Optical Fiber Tap

Splitter: 104: 1 x 1:4 High Density STARTAP
204: 2 x 1:2 High Density STARTAP

MON Port Value: 10: 10%
20: 20%
30: 30%
.....

Fiber Type: _ : Singlemode
M : Multimode(OM3)
M4 : Multimode(OM4)

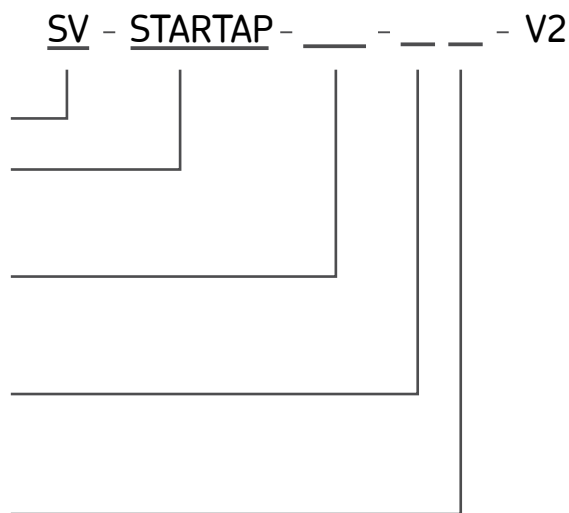

Example:

SV-STARTAP-204-50-V2

Starview 2 x 4 High Density STARTAP 9/125um singlemode splitter with 2 x Input port (LC/ UPC) and 2 x 50% MON port (LC/ UPC) and 2 x 50% output ports (LC/ UPC)

Cables

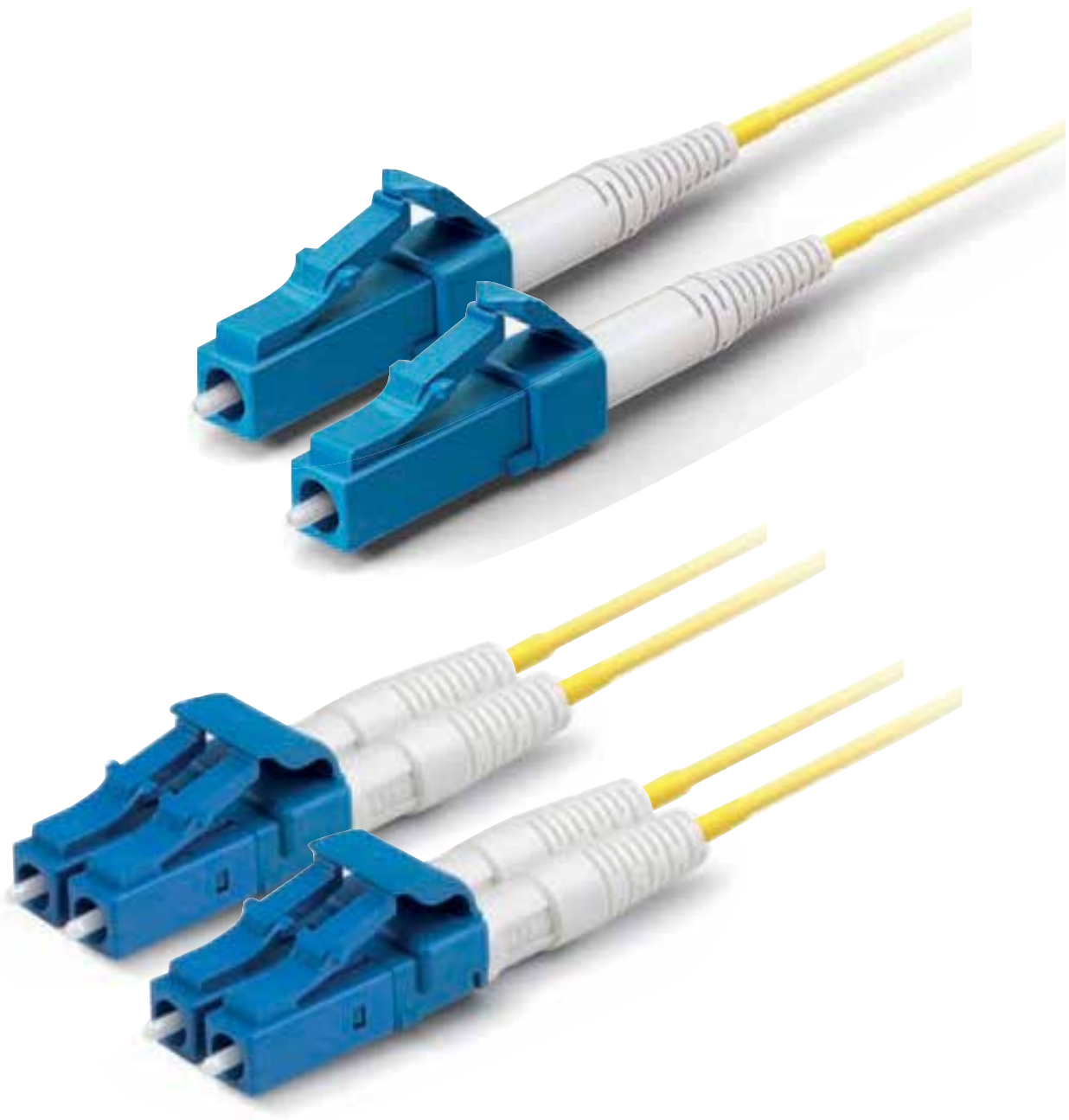

- Available with various optical connectors, i.e. LC, SC, FC, E2000, ST and APC or UPC type
- Bend-Insensitive Fiber with 2mm or 3mm type diameter
- Available with simplex and duplex fiber types include OM3/ OM4 multimode 50/125 μ m and Singlemode 9/125 μ m
- Factory terminated and 100% tested
- Individually packaged with test results included



LC APC 2mm



LC UPC 900µm



SC APC 2mm



SC UPC 900µm



FC APC 2mm



FC UPC 900µm



SVI Patch cord using the highest grade connector available. They are used for referencing and for mass-production

Features

- Compliant with: IEEE 802.3u, IEC 60794, TIA/EIA-568.B.3
- Optical performance 100% factory tested.
- Standard lengths of SC and FC, ST assemblies in stock.
- Customized assemblies are available in a variety of lengths, connector styles and performance.
- Precision ceramic ferrule with end face geometry per IEC proposal.

Applications

- Telecommunications network
- Active device termination
- CATV networks
- Local area networks

How to choose optical fiber patch cord

The Optical Fiber Patch cord is available for any kind of configurations you need.

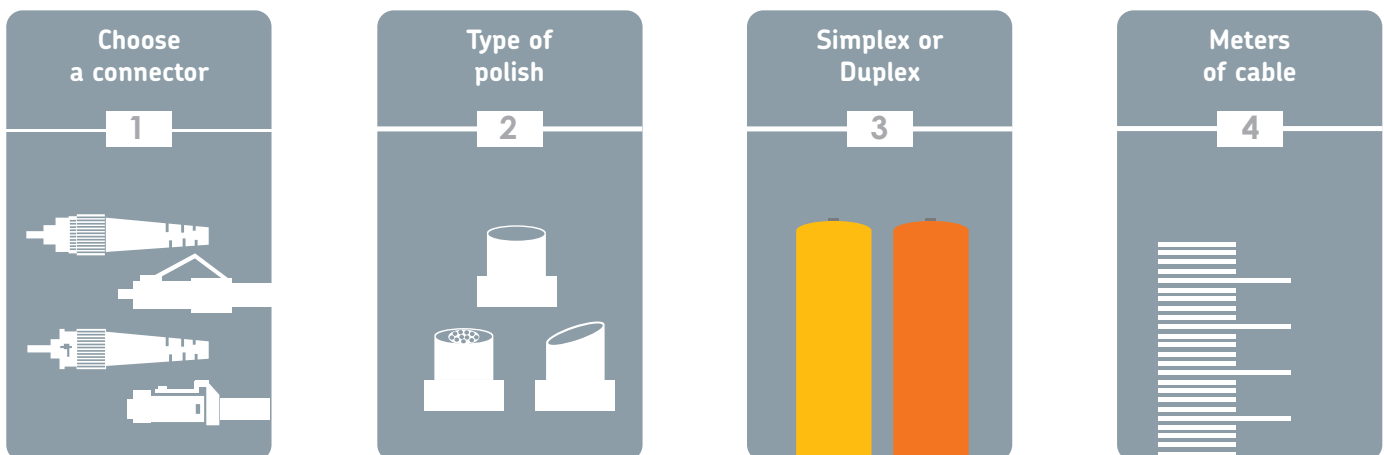

Simplex Single Mode Patch Cord



Features

- The Single Mode Jumper construction is designed to support tough usage, high performance interconnections, easy installation, and saving time
- IEEE 802.3u, IEC 60794, TIA/EIA-568.B.3 compliant
- 9/125µm Single Mode that offers a great wide broadband
- Telcordia GR-326 and IEEE 802.3u/802.3x/802.3z/802.3j standards tested
- 9/125µm Single Mode Riser
- 2mm, and 3mm Simplex
- Fibers offers low insertion loss once joined to connector
- Different type of terminations SC to ST, LC to FC, etc.

Specifications

Norms and Standards	Telcordia GR-326, IEEE 802.3u/802.3x/802.3z/802.3j, IEC 60794, TIA/EIA-568.B.3		
Fiber Jacket	Diameter	3mm ± 0.05mm	2mm ± 0.05mm
	Thickness	0.80mm ± 0.80mm	0.60mm ± 0.50mm
	Temperature	-20°C up to 85°C	
Fiber optic	Core diameter	Fiber: 9/125µm	Value: ± 0.70mm
	Cladding diameter	125.0 ± 2.0µm	
	Core concentricity	≤ 1.5µm	
	Cladding concentricity	≤ 1.0%	
	Wavelength	Single mode:	1310 nm
Maximum value	dB/Km	≤ 0.4	≤ 0.3
Recommended Light source	Single mode:	Laser	

Ordering Information

Example:

SV-CORD-LCULCU-SM1MS2

Starview Fiber Patchcord with LC/UPC to LC/UPC connector, Singlemode 9/125um 1 meter Simplex with type 2mm bend-insensitive fiber

- Manufacturer: Starview International
- Type: Optical Fber Patchcord
- Connector Type #1: SC:SC; FC:FC; ST:ST; LC:LC;
- Polishing Grade #1: U:UPC; A: APC
- Connector Type #1: SC:SC; FC:FC; ST:ST; LC:LC;
- Polishing Grade #1: U:UPC; A:APC
- Fiber Type: SM: Singlemode; MM: Multimode
- Length: (m) 1-99 M
- Cord Type: S: Simplex Type; D: Duplex Type
- Cord Diameter: (mm) 2; 3;

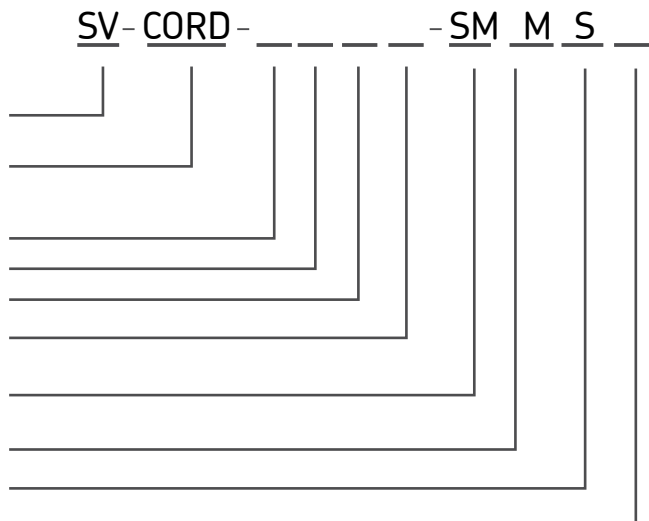

Simplex Multi Mode Patch Cord



Features

- Different type of terminations SC to ST, LC to FC, etc.
- ANSI/TIA/EIA-568.B.3 compliant
- 50/125µm Multimode Riser
- 2mm, and 3mm Simplex / Duplex
- IEEE 802.3u, IEC 60794, TIA/EIA-568.B.3 compliant
- Electric interference immune
- Fibers offers low insertion loss once joined to connector
- Telcordia GR-326 tested
- Lab connectorized, each jumpers includes a quality certificate to state measuring standards

Specifications

Norms and Standards	Telcordia GR-326, IEEE 802.3u/802.3x/802.3z/802.3j, IEC 60794, TIA/EIA-568.B.3		
Fiber Jacket	Diameter	3mm ± 0.05mm	2mm ± 0.05mm
	Thickness	0.80mm ± 0.80mm	0.60mm ± 0.50mm
	Temperature	-20°C up to 85°C	
Fiber optic	Core diameter	Value: ± 0.70mm	Fiber: 50/125µm
	Cladding diameter	125.0 ± 2.0µm	
	Core concentricity	≤ 1.5µm	
	Cladding concentricity	≤ 1.0%	
	Wavelength	Multimode:	850 nm
Maximum value	dB/Km	≤ 3.5	≤ 1.5
Recommended Light source	Multimode:	LED or VCSEL	

Ordering Information

Example:

SV-CORD-LCULCU-MM1MS2

Starview Fiber Patchcord with LC/UPC to LC/UPC connector;
Multimode 50/125µm 1 meter Simplex with type 2mm,
OM3 bend-insensitive fiber

Manufacturer: Starview International
Type: Optical Fiber Patchcord
Connector Type #1: SC:SC; FC:FC; ST:ST;
LC:LC;
Polishing Grade #1: U:UPC; A: APC
Connector Type #1: SC:SC; FC:FC; ST:ST;
LC:LC;
Polishing Grade #1: U:UPC; A:APC
Fiber Type: SM: Singlemode
MM: Multimode
Length: (m) 1-99 M
Cord Type: S: Simplex Type
D: Duplex Type
Cord Diameter: (mm) 2; 3;

SV - CORD - - - - - MM M S

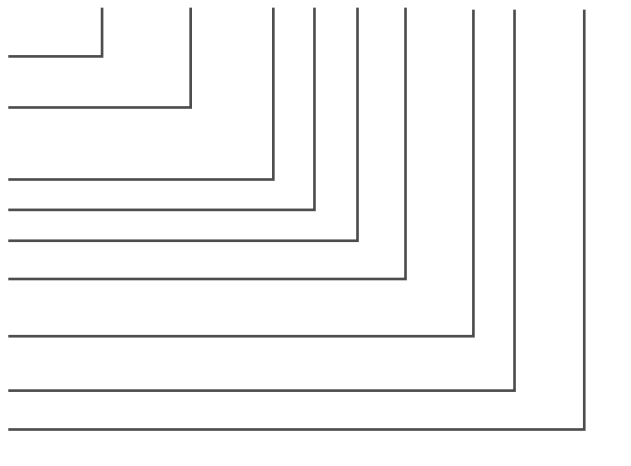

Duplex Single Mode Patch Cord



Features

- Different type of terminations SC to ST, LC to FC, etc.
- ANSI/TIA/EIA-568.B.3 compliant
- 9/125µm Singlemode Riser
- 2mm, and 3mm Simplex / Duplex
- IEEE 802.3u, IEC 60794, TIA/EIA-568.B.3 compliant
- Electric interference immune
- Fibers offers low insertion loss once joined to connector
- Telcordia GR-326 tested
- Lab connectorized, each jumpers includes a quality certificate to state measuring standards

Specifications

Norms and Standards	Telcordia GR-326, IEEE 802.3u/802.3x/802.3z/802.3j, IEC 60794, TIA/EIA-568.B.3		
Fiber Jacket	Diameter	3mm ± 0.05mm	2mm ± 0.05mm
	Thickness	0.80mm ± 0.80mm	0.60mm ± 0.50mm
	Temperature	-20°C up to 85°C	
Fiber optic	Core diameter	Fiber: 9/125µm	Value: ± 0.70mm
	Cladding diameter	125.0 ± 2.0µm	
	Core concentricity	≤ 1.5µm	
	Cladding concentricity	≤ 1.0%	
	Wavelength	Single mode:	1310 nm
	Maximum value	dB/Km	≤ 0.4 ≤ 0.3
	Recommended Light source	Single mode:	Laser

Ordering Information

Example:

SV-CORD-LCULCU-SM1MD2

Starview Fiber Patchcord with LC/UPC to LC/UPC connector,
Singlemode 9/125um 1 meter Duplex with type 2mm
bend-insensitive fiber

- Manufacturer: Starview International
- Type: Optical Fber Patchcord
- Connector Type #1: SC:SC; FC:FC; ST:ST; LC:LC;
- Polishing Grade #1: U:UPC; A: APC
- Connector Type #1: SC:SC; FC:FC; ST:ST; LC:LC;
- Polishing Grade #1: U:UPC; A:APC
- Fiber Type: SM: Singlemode
MM: Multimode
- Length: (m) 1-99 M
- Cord Type: S: Simplex Type
D: Duplex Type
- Cord Diameter: (mm) 2; 3;

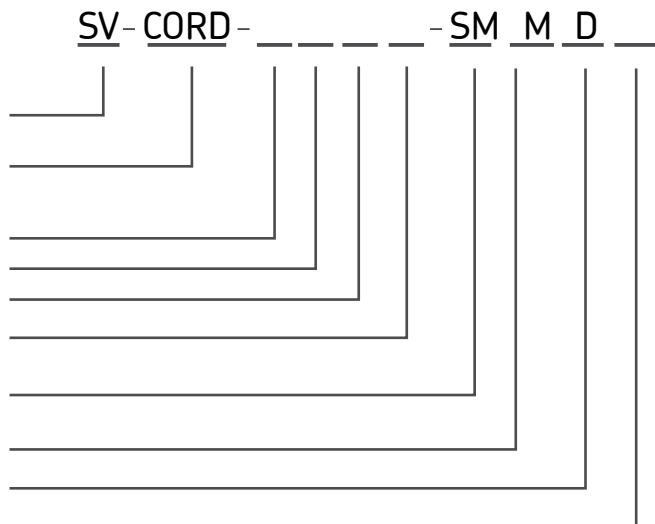

Duplex Multi Mode Patch Cord



Features

- Different type of terminations SC to ST, LC to FC, etc.
- ANSI/TIA/EIA-568.B.3 compliant
- 50/125µm Multimode Riser
- 2mm, and 3mm Simplex / Duplex
- IEEE 802.3u, IEC 60794, TIA/EIA-568.B.3 compliant
- Electric interference immune
- Fibers offers low insertion loss once joined to connector
- Telcordia GR-326 tested
- Lab connectorized, each jumpers includes a quality certificate to state measuring standards

Specifications

Norms and Standards	Telcordia GR-326, IEEE 802.3u/802.3x/802.3z/802.3j, IEC 60794, TIA/EIA-568.B.3		
Fiber Jacket	Diameter	3mm ± 0.05mm	2mm ± 0.05mm
	Thickness	0.80mm ± 0.05mm	0.60mm ± 0.05mm
	Temperature	-20°C up to 85°C	
Fiber optic	Core diameter	Value: ± 0.70mm	Fiber: 50/125µm,
	Cladding diameter	125.0 ± 2.0µm	
	Core concentricity	≤ 1.5µm	
	Cladding concentricity	≤ 1.0%	
	Wavelength	Multimode:	850 nm 1300 nm
	Maximum value	dB/Km	≤ 3.5 ≤ 1.5
	Recommended Light source	Multimode:	LED or VCSEL

Ordering Information

Example:

SV-CORD-LCULCU-MM1MD23

Starview Fiber Patchcord with LC/UPC to LC/UPC connector;
Multimode 50/125µm 1 meter Duplex with type 2mm, OM3
bend-insensitive fiber

Manufacturer:	Starview International
Type:	Optical Fiber Patchcord
Connector Type #1:	SC:SC; FC:FC; ST:ST; LC:LC;
Polishing Grade #1:	U:UPC; A: APC
Connector Type #2:	SC:SC; FC:FC; ST:ST; LC:LC;
Polishing Grade #2:	U:UPC; A:APC
Fiber Type:	SM: Singlemode MM: Multimode
Length:	(m) 1-99 M
Cord Type:	S: Simplex Type D: Duplex Type
Cord Diameter:	(mm) 2; 3;

SV - CORD - _____ - MM M D _____

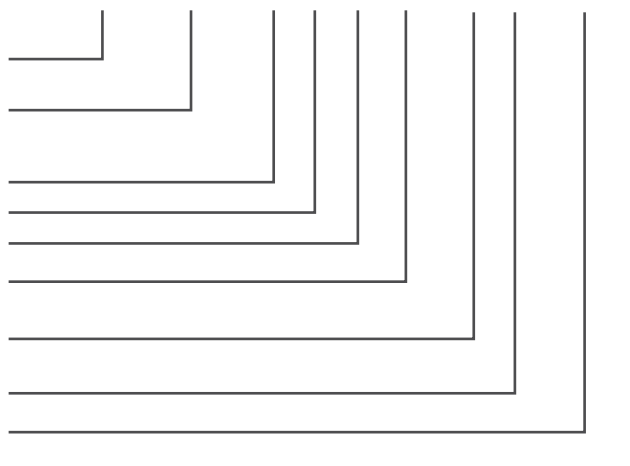

Copper Patch Cord



Features

- Snagless, molded boots provide strain relief and prevent kinking as well as snagless cable mining.
- All Cat5e cables tested to 350MHz; Cat6 cables tested to 250MHz.
- All have 4-pair, 24 AWG construction with RJ-45 connectors.
- Available in both straight or crossover pinning.

Specifications

Norms and Standards	Telcordia GR-326, IEEE 802.3u/802.3x/802.3z/802.3j, IEC 60794, TIA/EIA-568.B.3		
		CAT 5e	CAT 6
Cable Type		4-pair UTP	4-pair UTP
Core diameter		24 AWG, stranded	24 AWG, stranded
Jacket		PVC, 80C,OD=5.3 mm	PVC, 80C,OD=6.2 mm
Frequency		up to 350 MHz	up to 250 MHz
Impedance		100 15 ohms	100 15 ohms@ 100 MHz
Attenuation (max.)		24 dB/100 m @ 100 MHz; 49 dB/100 m @ 350 MHz;	24 dB/100 m @ 100 MHz; 39 dB/100 m @ 250 MHz
Temperature		-20°C up to 85°C	

Ordering Information

Example:

SV-CORD-RJ45S-CAT5E1M

Starview Copper Patchcord (Straight) with RJ45 connectors.
CAT5e, 1 meter

SV - CORD - RJ45

- Manufacturer: Starview International
- Type: Optical Fber Patchcord
- Connector Type: RJ-45
- Cable Type: S : straight -through
C : crossover
- Cable Specs: CAT5E: CAT 5e
CAT6: CAT 6
- Length: (m) 1-99 M

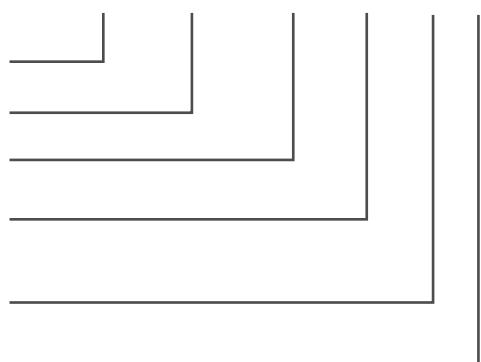

Armour Fiber Patchcord

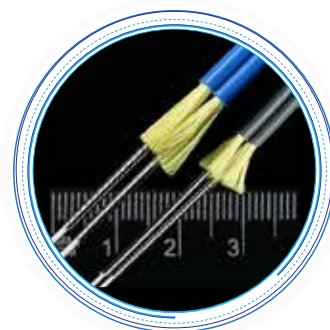
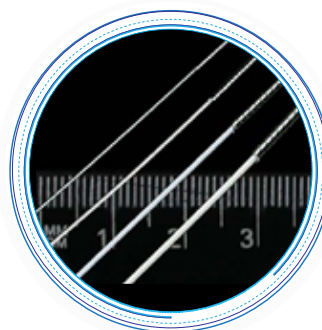

Unit of the Armored Optical Fiber

Duplex Armored Optical Fiber Cable

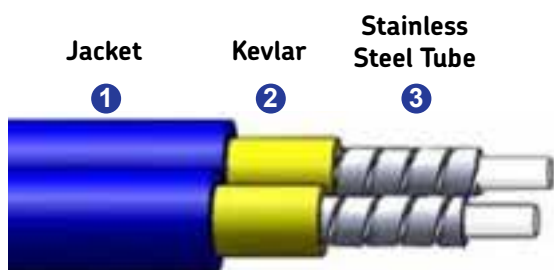

Specifications

Norms and Standards	Telcordia GR-326, IEEE 802.3u/802.3x/802.3z/802.3j, IEC 60794, TIA/EIA-568.B.3		
Fiber Jacket	Diameter	3mm ± 0.05mm	
	Thickness	0.80mm ± 0.80mm	
	Temperature	-20°C up to 85°C	
Fiber optic	Core diameter	Fiber:	Value:
		50/125µm; 9/125µm; 62.5/125µm ± 0.70mm	
	Cladding diameter	125.0 ± 2.0µm	
	Core concentricity	≤ 1.5µm	
	Cladding concentricity	≤ 1.0%	
Wavelength	Multimode:	850 nm	1300 nm
	Single mode:	1310 nm	1550 nm
Maximum value	Multimode: dB/Km	≤ 3.5	≤ 1.5
	Single mode: dB/Km	≤ 0.3	≤ 0.2
Recommended Light source	Multimode:	LED or VCSEL	
	Single mode:	Laser	

Armour Fiber Patchcord



Features

- Resist damage by improper twist
- Resistance of pressure and rodent bite
- Fibers offers low insertion loss once joined to connector
- IEEE 802.3u, IEC 60794, TIA/EIA-568.B.3 compliant
- 50/125Åµm Multi Mode, 62.5/125Åµm Single Mode, 3mm Simplex
- Stainless steel tube inside the outer jacket
- Additional durability and protection as well as light weight.
- Different type of terminations SC to ST, LC to FC, etc.

Ordering Information

Example:

SV-ACORD-LCUFCU-SM3MD2

Starview Armour Fiber Patchcord with LC/UPC to FC/UPC connector, Singlemode 9/125um 3 meter Duplex with type 2mm bend-insensitive fiber

Manufacturer:	Starview International
Type:	Optical Fber Patchcord
Connector Type #1:	SC:SC; FC:FC; ST:ST; LC:LC;
Polishing Grade #1:	U:UPC; A: APC
Connector Type #1:	SC:SC; FC:FC; ST:ST; LC:LC;
Polishing Grade #1:	U:UPC; A:APC
Fiber Type:	SM: Singlemode MM: Multimode
Length:	(m) 1-99 M
Cord Type:	S: Simplex Type D: Duplex Type
Cord Diameter:	(mm) 2; 3;

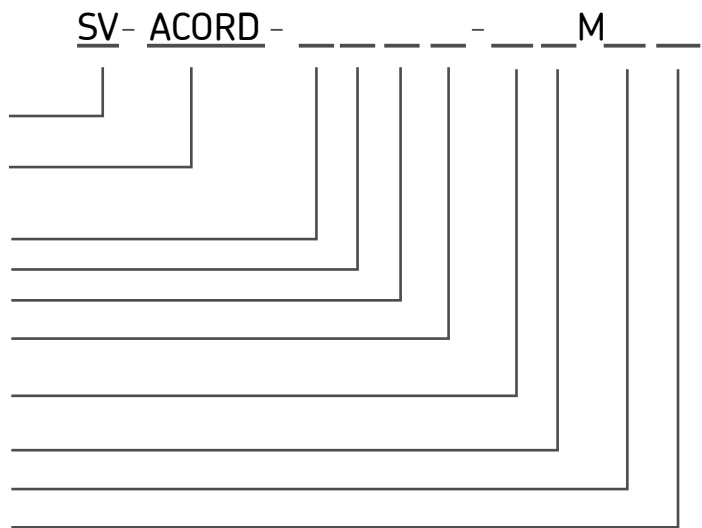

MPO Cables

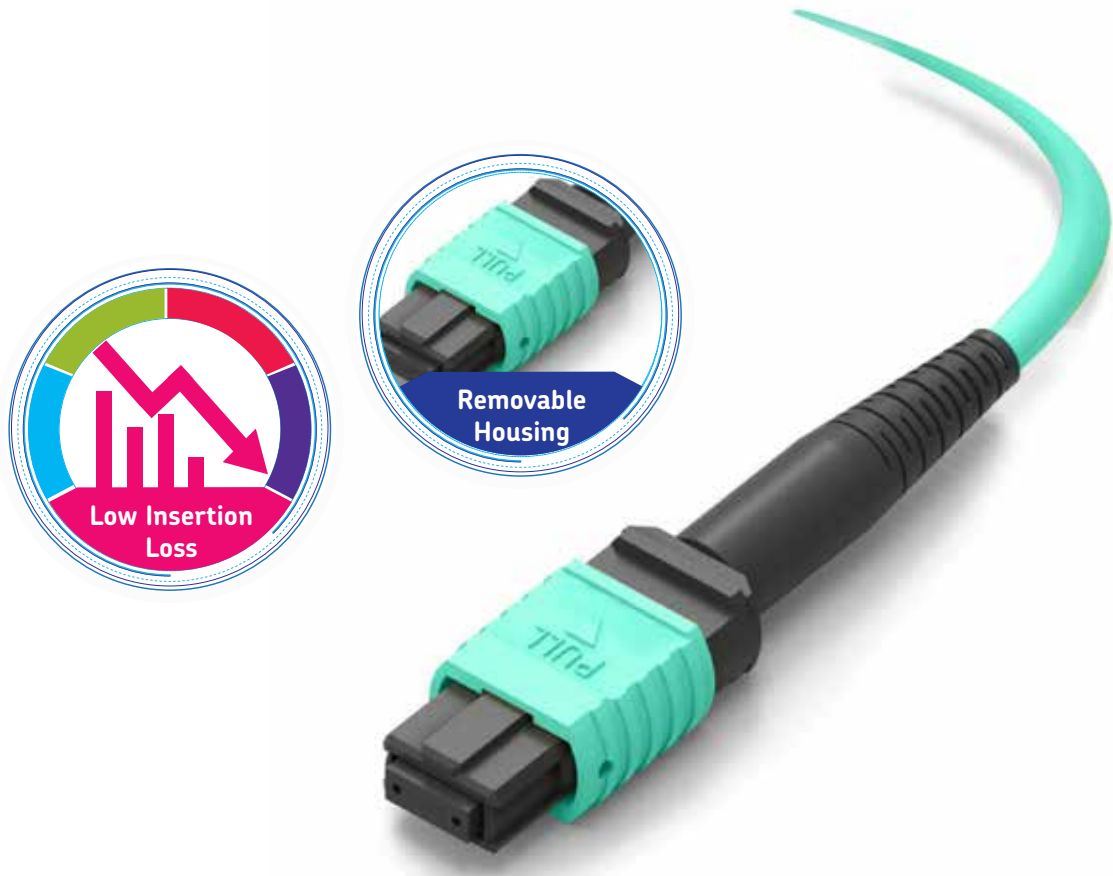

Specifications

Norms and Standards	Telcordia GR-326, IEEE 802.3u/802.3x/802.3z/802.3j, IEC 60794, TIA/EIA-568.B.3		
Fiber Jacket	Diameter	3mm ± 0.05mm	2mm ± 0.05mm
	Thickness	0.80mm ± 0.80mm	0.60mm ± 0.50mm
	Temperature	-20°C up to 85°C	
Fiber optic	Core diameter	Fiber:	Value: ± 0.70mm
		50/125µm; 9/125µm	
	Cladding diameter	125.0 ± 2.0µm	
	Core concentricity	≤ 1.5µm	
	Cladding concentricity	≤ 1.0%	
	Wavelength	Multimode:	850 nm 1300 nm
		Single mode:	1310 nm 1550 nm
	Maximum value	Multimode: dB/Km	≤ 3.5 ≤ 1.5
		Single mode: dB/Km	≤ 0.3 ≤ 0.2
	Recommended Light source	Multimode:	LED or VCSEL
		Single mode:	Laser

MPO Cable



Features

- Female MPO (Multi Push Optics) connector
- Customize fiber optic cable length
- 12 and 24 core cable fiber types. Also available with MPO to LC/JPC breakout cable
- Uses 50/125um OM3 /OM4 multimode bend-insensitive fiber or singlemode 9/125um (G652D, G657A1) bend-insensitive fiber with 2mm diameter
- Comply with IEC 61754-7, Telecordia GR-1435-CORE
- Supports 40G/ 100G applications
- Factory terminated and 100% tested
- Individually packaged with test results included

Ordering Information

Example:
SV-CORD-12MPF12MPF-MM1MD23
 Starview Fiber Patchcord Female with MPO-12 (Female) to MPO-12 (Female), multimode 50/125um 1 meter with type 2mm OM3 bend-insensitive fiber

Manufacturer:	Starview International
Type:	Optical Fiber Patchcord
Type #1:	12MP: MPO-12; 24MP: MPO-24
Connector Type #1:	F : female
Type #2:	12MP: MPO-12; 24MP: MPO-24
Connector Type #2:	F : female
Fiber Type:	SM: Singlemode MM: Multimode
Length:	(m) 1-99 M
Cord Type:	S: Simplex Type D: Duplex Type
Cord Diameter:	(mm) 2; 3;
Bend-insensitive:	3: OM3 4: OM4

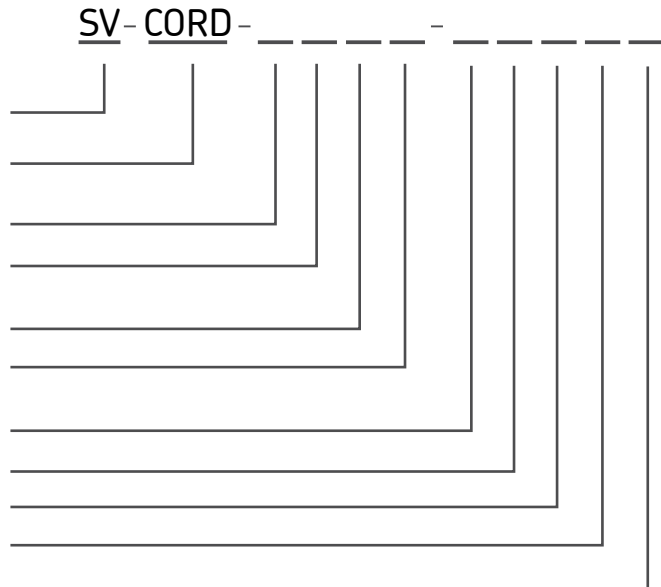

LC-HD High Density LC connector patch cord

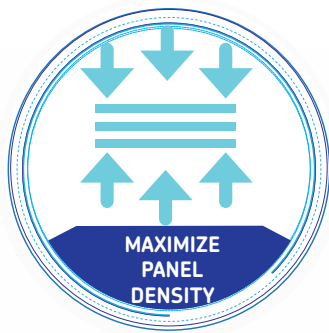

LC-HD SIMPLEX
PULL TAB



LC-HD DUPLEX
PUSH-PULL TAB

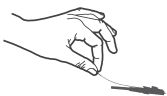

Easy to release trigger connector

The LC-HD's lever design utilizes a flexible "pull-tab" allowing for the connector to be disengaged easily from densely loaded panels without the need for special tools. "Pull-Tabs" are available in three standard lengths and multiple colors.



Stackable adapters

The LC adapter spacing was limited by the room required to reach LC connectors with the human fingers or with special tools. The overall height of standard LC connectors also required a small vertical space above and below the LC adapters. The low profile Senko LC-HD, together with its pull tab allow the LC adapter to be stacked with absolutely no vertical space.



60% increase in density

The LC-HD connector can be removed using a simple pull tab, it eliminates the need for finger access to the LC connectors latch mechanism, therefore LC adapters can now be mounted much closer than spacing required in the past.

LC-HD High Density LC connector patch cord



Features

- LC-HD's lever design utilizes a flexible "pull-tab" allowing for the connector to be disengaged easily from densely loaded panels without the need for special tools.
- IEEE 802.3u, IEC 60794, TIA/EIA-568.B.3 compliant
- 9/125µm Single Mode that offers a great wide broadband
- Telcordia GR-326 and IEEE 802.3u/802.3x/802.3z/802.3j standards tested
- 9/125µm Single Mode
- 2mm, and 3mm Simplex

Ordering Information

Example:

SV-CORD-HLCUHLCU-SM3MS2

Starview Fiber Patchcord with High Density LC/UPC to High Density LC/UPC connector. Singlemode 9/125µm 3 meter Simplex with type 2mm bend-insensitive fiber

		SV - CORD - H	H	-	M
Manufacturer:	Starview International	_____	_____	_____	_____
Type:	Optical Fber Patchcord	_____	_____	_____	_____
Type:	high density fiber patch cord	_____	_____	_____	_____
Connector Type #1:	LC:LC;	_____	_____	_____	_____
Polishing Grade #1:	U:UPC;	_____	_____	_____	_____
Type:	high density fiber patch cord	_____	_____	_____	_____
Connector Type #1:	LC:LC;	_____	_____	_____	_____
Polishing Grade #1:	U:UPC;	_____	_____	_____	_____
Fiber Type:	SM: Singlemode MM: Multimode	_____	_____	_____	_____
Length:	(m) 1-99 M	_____	_____	_____	_____
Cord Type:	S: Simplex Type D: Duplex Type	_____	_____	_____	_____
Cord Diameter:	(mm) 2; 3;	_____	_____	_____	_____

Accessories

Optical Connector
Optical Attenuators
Optical Adapters

Highest quality
and performance

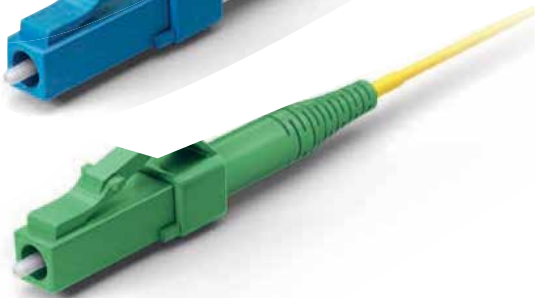
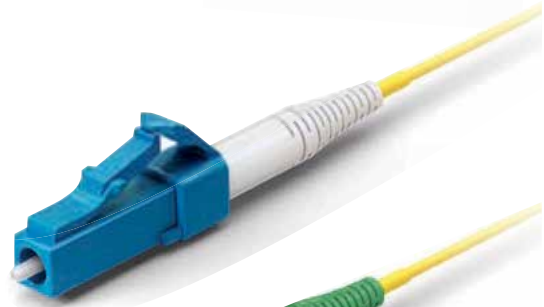

- Cost Effective and fast lead time
- Low insertion loss
- Customized cable length and connectors
- Factory terminated and 100% tested
- Individually packaged with test results included

Accessories

Optical Connector



Features

- SC; LC; FC; ST Simplex or Duplex
- ANSI, IEC, TIA/EIA, NTT and JIS standard compatible
- Precision mechanical dimensions
- Zirconia ferrule PC or 8 degree APC diameter 125-128 μm high concentricity
- Single mode, Multimode and Angle PC
- Multi-piece type or one-piece type is available
- All parts compliant with ROHS

Applications

- Telecommunications network
- Active device termination
- CATV networks
- Local area networks.
- Broadband
- FTTH

Ordering Information

Example:

SV-CONNECTOR-LC-SMD

Starview Singlemode LC connector, Simplex Type.

Manufacturer: Starview International
 Type: Optical Connector
 Connector Type: SC:SC; FC:FC; ST:ST; LC:LC;
 Ferrule: SM: Singlemode
 MM: Multimode
 AP: Apc
 Type: S: Simplex Type
 D: Duplex Type

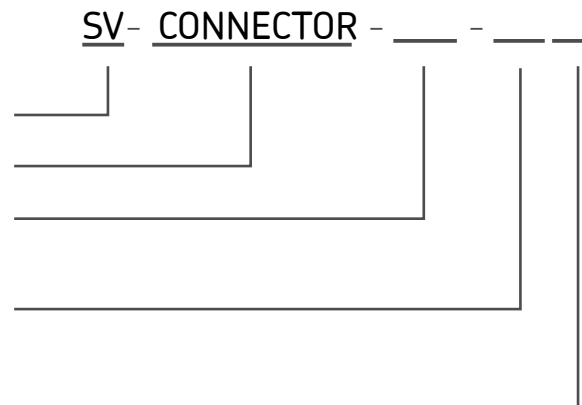

Highest quality and performance



LC UPC 900µm



FC UPC 900µm



SC UPC 900µm



LC APC 2mm



FC APC 2mm



SC APC 2mm

Specifications

Parameters	SC	LC	FC	ST
Fastening	Push-pull	Plug-in	Threaded coupling	Bayonet fitting
Body	Plastic	Plastic	Metallic	Metallic
Ferrule	Ceramic	Ceramic	Ceramic	Ceramic
Ferrule diameter	2.5mm	1.5mm	2.5mm	2.5mm
Polish	PC/UPC/APC	PC/UPC	PC/UPC/APC	PC/UPC
Ferrule tolerance	125.0 ± 1µm	125.0 ± 1µm	125.0 ± 1µm	125.0 ± 1µm
	126.0 ± 1µm MM	126.0 ± 1µm MM	126.0 ± 1µm MM	126.0 ± 1µm MM
Insertion loss	≤ 0.20 dB PC	≤ 0.20 dB PC	≤ 0.20 dB PC	≤ 0.20 dB PC
	≤ 0.30 dB UPC	≤ 0.30 dB UPC	≤ 0.30 dB UPC	≤ 0.30 dB UPC
	≤ 0.45 dB APC		≤ 0.45 dB APC	
Return loss	≤ 0.45 dB UPC	≤ 0.45 dB UPC	≤ 0.45 dB PC	≤ 0.45 dB PC
	≤ 0.50 dB APC		≤ 0.50 dB APC	
Temperature	-40°C to 85°C	-40°C to 85°C	-40°C to 85°C	-40°C to 85°C
Durability	± 1db 500	± 1db 500	± 1db 500	± 1db 500
	Insertions	Insertions	Insertions	Insertions

Accessories

Optical Adapters



Features

- Types: FC-LC, FC-SC, FC-ST, SC-ST...
- Low insertion loss, high return loss
- Good compatibility
- High precision of mechanical dimensions
- High reliability & stability
- Ceramic or Bronze Sleeve
- PC;APC;UPC optional
- Simplex / Duplex

Applications

- Local Area Network
- CATV System
- Telecommunication Networks
- Equipment Test

Ordering Information

Example:

SV-ADAPTER-LCULCU-SMS

Starview adapter with LC/UPC (Female) to LC/UPC (Female).
Singlemode type Simplex connector

Manufacturer:	Starview International
Type:	Optical Adapter
Connector Type #1:	SC:SC; FC:FC; ST:ST; LC:LC;
Polishing Grade #1:	U:UPC; A: APC
Connector Type #2:	SC:SC; FC:FC; ST:ST; LC:LC;
Polishing Grade #2:	U:UPC; A:APC
Ferrule:	SM: Singlemode MM: Multimode
Type:	S: Simplex Type D: Duplex Type

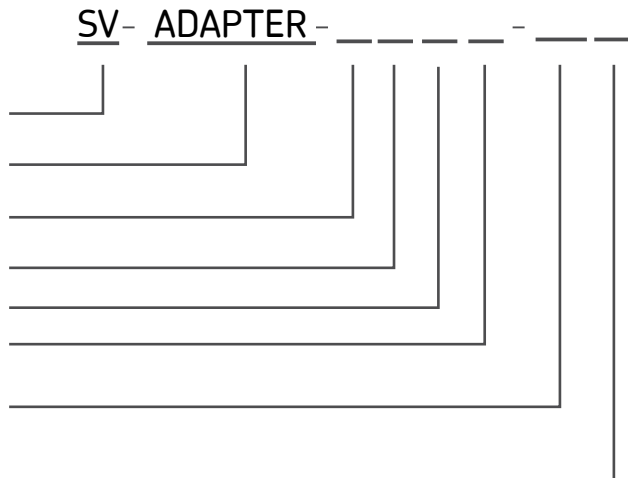



SC-LC Adapter

SVI highest quality adapter series available. They are used for referencing and for mass-production



FC-LC Adapter



SC-LC Adapter



FC-LC Adapter

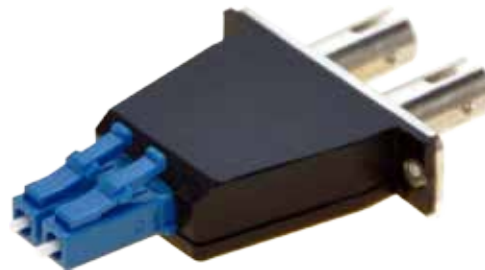

ST-LC Adapter

Specifications

Fastening	LC, SC, FC, ST, SC-ST, FC-ST, FC-SC, FC-LC,			
Body	SM			MM
Ferrule	PC	UPC	APC	PC
Insertion Loss (Typical)	≤ 0.3dB	≤ 0.2dB	≤ 0.3dB	≤ 0.2dB
Return Loss	≥ 45dB	≥ 50dB	≥ 60dB	≥ 30dB
Exchangeability	≤ 0.2dB			
Repeatability	≤ 0.2dB			
Temperature	-40°C to 85°C			

Accessories

Optical Attenuator



- SC



- LC



- FC

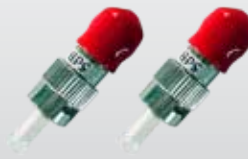

- ST

Features

- Low back reflection and Low PDL
- High precision attenuation value
- Precision control of attenuation range
- Wide attenuation range
- Precision ceramic ferrule
- FC, SC, ST, LC ... optional
- Plastic or metal housing material

Applications

- Fiber optical telecommunication system
- Fiber optical CATV
- Fiber optical sensor
- Testing equipment

Ordering Information

Example:

SV-ATT-LCU-SM1

Starview Attenuator with LC/UPC connector, Singlemode type
1dB Attenuation

Manufacturer:	Starview International
Type:	Optical attenuator
Connector Type:	SC:SC; FC:FC; ST:ST; LC:LC;
Polishing Grade:	U:UPC; A: APC
Type:	SM: Singlemode MM: Multi mode
Attenuating Vaule:	01: 1db 03: 3db 05: 5db 10: 10db 15: 15db 20: 20db

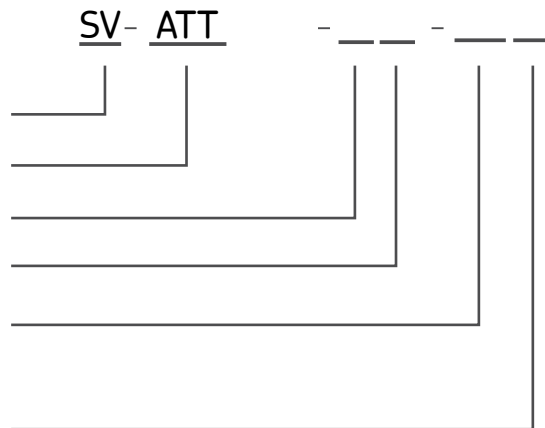

SC-APC LC-UPC Attenuators

Highest quality and performance

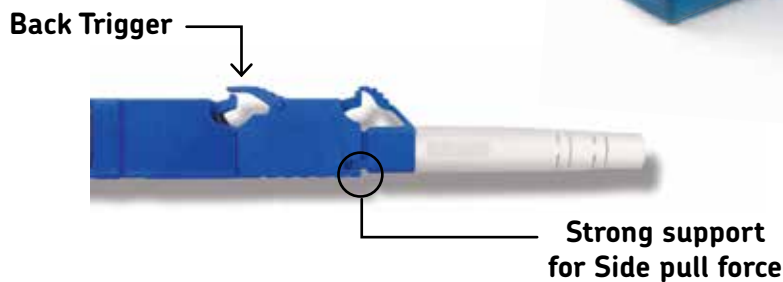

Specifications

Parameters	SC	LC	FC	ST
Fastening	1310nm/1550nm	1310nm/1550nm	1310nm/1550nm	1310nm/1550nm
Body	1-10dB(1dB step).	1-10dB(1dB step).	1-10dB(1dB step).	1-10dB(1dB step).
Ferrule	15, 20, 25, 30dB	15, 20, 25, 30dB	15, 20, 25, 30dB	15, 20, 25, 30dB
Ferrule diameter	≥ 50 dB PC	≥ 50 dB PC	≥ 50 dB PC	≥ 50 dB PC
Polish	≥ 55 dB UPC	≥ 55 dB UPC	≥ 55 dB UPC	≥ 55 dB UPC
Ferrule tolerance	≥ 60 dB APC	≥ 60 dB APC	≥ 60 dB APC	≥ 60 dB APC
	≤ 1.0 (11-30dB)	≤ 1.0 (11-30dB)	≤ 1.0 (11-30dB)	≤ 1.0 (11-30dB)
Insertion loss	-40°C to 85°C	-40°C to 85°C	-40°C to 85°C	-40°C to 85°C

Cleaner

MPO Cleaners
Fiber Optic Cleaners
Transceiver Cleaners

Smart cleaner



Fiber Optic Cleaners



Transceiver Cleaners



MPO Cleaners

Fiber Optical Connector Cleaners



SC/LC Connector Cleaners
Replaceable Cartridge Type

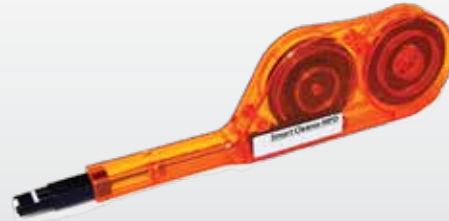

MPO Connector Cleaner
Increase Equipment Reliability

Specifications

750 times + CLEANINGS FOR EACH CARTRIDGE		
Compatible	LC	SC
Connectors	PC and APC	PC and APC



Specifications

600 times + CLEANINGS	
Compatible	MPO Connectors, MTP
Connectors	Connectors® Plug and Port



The Smart Cleaners are dry cloth cleaners specially designed to clean single fiber connectors residing in an adapter, faceplate or bulkhead. The Smart Cleaners are simple to use and highly effective at removing oil and dust contaminants that can negatively impact optical performance.

In response to the special cleaning needs of multi-fiber optical connectors, We are introducing a new cleaner for MPO optical connectors. By further expanding its lineup of optical connector cleaners, We are able to respond to an even wider range of its customers needs.

Ordering Information

SV-CLEANER-LC	Starview Replaceable Cleaner for LC Connector, tape width 1.25mm
SV-CLEANER-SC	Starview Replaceable Cleaner for SC Connector, tape width 2.5mm
SV-CARTRIDGE-LC	Starview Cleaner Replaceable Cartridge for LC Connector, tape width 1.25mm, c/w 3pcs per set
SV-CARTRIDGE-SC	Starview Cleaner Replaceable Cartridge for SC Connector, tape width 2.5mm, c/w 3pcs per set
SV-CLEANER-MPO	Starview Fixed Cleaner for MPO Connector

Transceiver Cleaners



For Cleaning SFP Transceivers with Adhesive Technology

Features

- Designed to clean fiber stub inside SFP transceiver port
- Adhesive technology leaves no scratches or residue on fiber stub surface
- Anti-static materials to protect transceivers from ESD
- Can be used for the other LC connector compliant transceivers

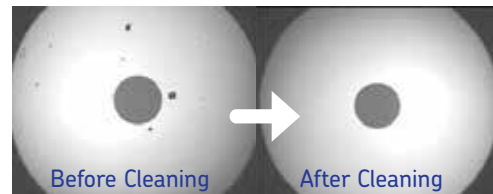

Design

The absorption element accesses to fiber stub inside SFP transceiver port and removes dust and residue which cannot be cleaned by wipe type cleaners.

Usage

Insert the tip of the cleaner into transceiver port. Push the stick until the tip touches the surface.

Ordering Information

SV-CLEANER-SFP-LC	Starview SFP Transceiver Cleaning "Stick" with Adhesive Technology for Cleaning SFP Transceiver with LC Connector
-------------------	---

MPO Cleaners



For Cleaning the Entire MPO
Endface Pin to Pin

Features

- Cleans entire MPO Endface including PIN area's
- No solvent needed
- Cleans Oil, Dust and Dirt Particulates
- Easy to use, PUSH on, and release to clean

Usage

Step 1:

Sticker cleaner contains 10 "Stick" cleaning area

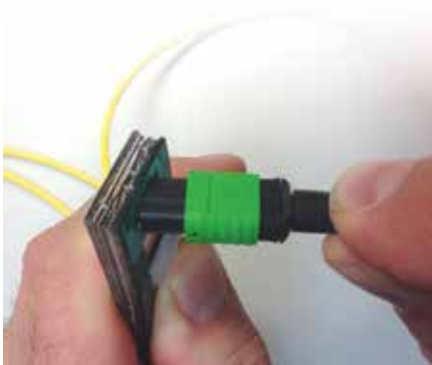

Step 2:

PUSH MT Ferrule against the stick surface for cleaner

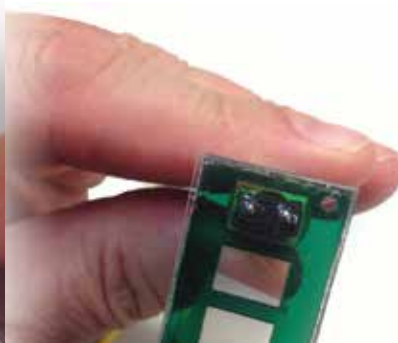

Step 3:

Remove the MT Ferrule, dirt and oil will be transferred from the ferrule to the cleaner

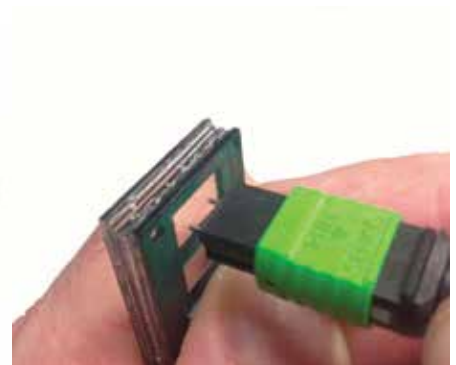

Effective for removing oil, dust, and dirt particulates that can have a negative impact on fiber optic performance.

Ordering Information

SV-CLEANER-MPO-STICK

Starview Sticker Cleaner containing 10 "Stick" cleaning area for cleaning entire MPO Endface including PIN area

PoE Extender



Outdoor use weather-proof
Single port PoE extender

Features

- Industrial Grade -40 to 70°C
- Mini-size, wall mounting
- Requires no external power supply
- Low power consumption, only 1.2W
- Auto-sensing PoE devices
- Compatibility with 802.3at and 802.3af

Outdoor use weather-proof Single port PoE extender- a quality product for PoE network point-to-point up to 500m. Works with PoE standards IEEE802.3af and IEEE802.3at. This device serves as a data switch port that is powered by PoE, and transmits it further on another 100m together with the data. Depending on the amount of power consumption, may use up to 4 extensions in the same chain, thereby increasing transmission distance up to 500m (1 class 82.3af, see table. "Maximum distance")

Typical connection diagram

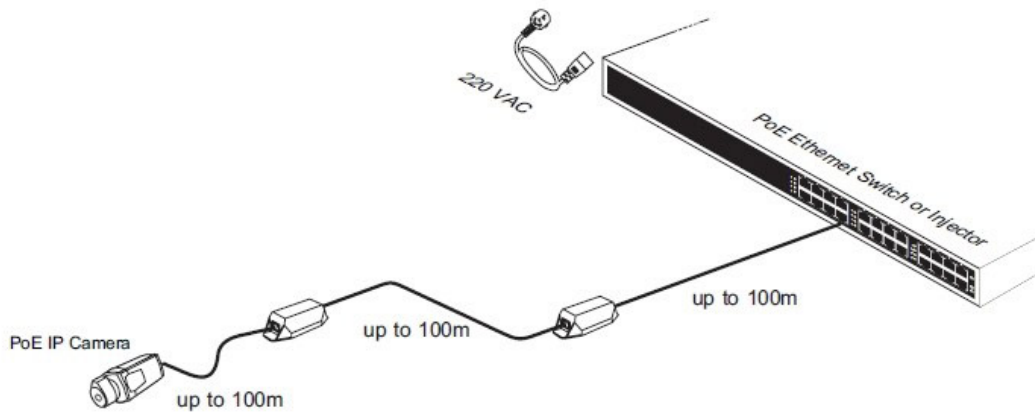

PoE Device (PD)	PoE Injector or Switch IEEE802.3af (max 15.4W)	PoE Plus Injector or Switch IEEE802.3at (max 30W)
IEEE802.3af class 1 no more than 4W	400m (3pcs PoE Extender)	500m (4pcs PoE Extender)
IEEE802.3af class 2 no more than 6W	300m (2pcs PoE Extender)	400m (3pcs PoE Extender)
IEEE802.3af class 0&3 no more than 12W	200m (1pcs PoE Extender)	300m (2pcs PoE Extender)
IEEE802.3at no more than 22W	Not applicable	200m (1pcs PoE Extender)

Ordering Information

SV-EXT-POE+	Starview Outdoor 10/100/1000Base-T 1-port PoE+ enabled Extender
-------------	---

Technical characteristics

Item	Description
No. of channels	1
Pass Through Data Rates	10/100/1000 Mbps half / full duplex
PoE input	Pin Assignment and Polarity: Both 1/2 (-), 3/6 (+) and 7/8 (-), 4/5 (+)
PoE output	Pin Assignment and Polarity: 1/2 (-), 3/6 (+) Output Power: up to 22W
Indicators	Power indicator: PoE enabled Network indicator: Link/Act
Connectors	Shielded RJ-45, EIA 568A and 568B
Network cables	Shielded category 5 (or higher)
Dimensions	185mm x 45mm x 45mm
Weight	0.22Kg
Mounting	Wall of shelf
Environment	Indoor or Outdoor
Environmental Conditions	Operating Ambient Temperature: -25 to 55°C Storage Temperature: -30 to 70°C
Compliance	IEEE802.3af (POE), IEEE802.3at (POE+)

Maximum Distances for Power Sources

Multiple PoE Extenders can be connected every 100 meters to obtain greater distances. The actual figures depend on operating conditions. The range is over 24 AWG or heavier Cat-5e or Cat-6 cable except where specified.

Examples for medium power PoE Devices (that are PoE Class 2, or require under 6 watts)

PoE Source			
PoE switch (802.3af, Output voltages 50V)	15W mid-span (802.3af, Output voltages 50V)	PoE+ switch (802.3at, Output voltages 50V)	30W mid-span (802.3at, Output voltages 50V)
Maximum Distances			
300m	300m	400m	400m

Examples for full power PoE Devices (that are PoE Class 0 or 3, or require under 12 watts)

PoE Source			
PoE switch (802.3af, Output voltages 50V)	15W mid-span (802.3af, Output voltages 50V)	PoE+ switch (802.3at, Output voltages 50V)	30W mid-span (802.3at, Output voltages 50V)
Maximum Distances			
200m	200m	300m	300m

Examples for PoE+ Devices (that are PoE Class 4 that under 22 watts, or 802.3at compliant)

PoE Source			
PoE switch (802.3af, Output voltages 50V)	15W mid-span (802.3af, Output voltages 50V)	PoE+ switch (802.3at, Output voltages 50V)	30W mid-span (802.3at, Output voltages 50V)
Maximum Distances			
Not applicable	Not applicable	200m	200m

PoE+ Injector

Increased Flexibility, Reduced Installation Time and Cost



Features

- 1 Port at 10/100/1000 Mbps
- Supports Up to 35W of POE power
- Compatible with IEEE 802.3af/at Standards
- Easy Installation - Parallel Slide-in Design for Multiple Units
- Safety Protection on Low Power Devices

Use PoE Injector with PD to expand your network to where there are no power lines or outlets, where you wish to fix devices such as APs, IP Cameras or P Phones, etc.

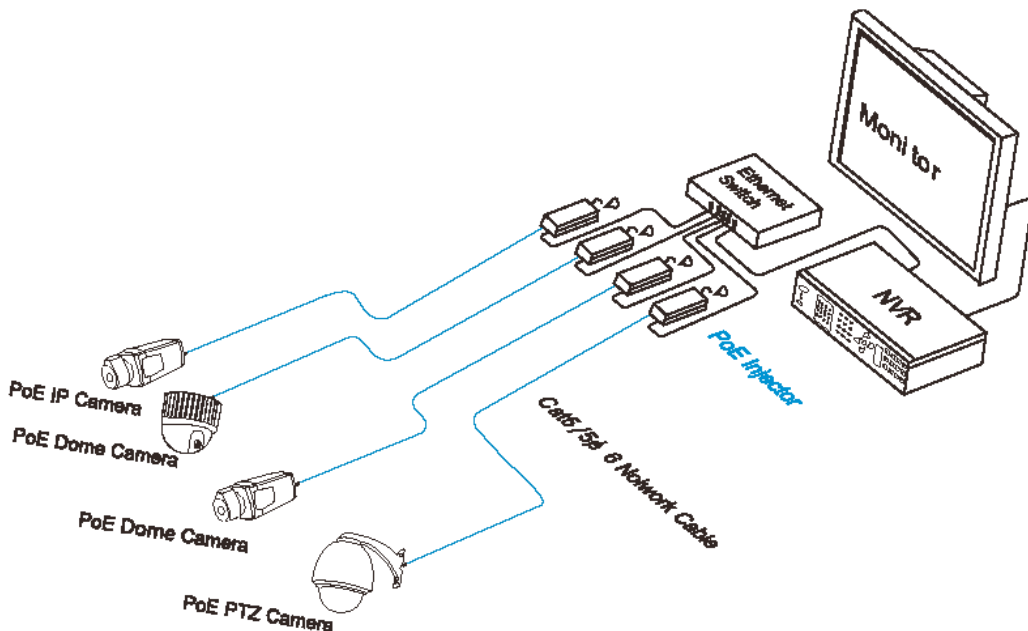

Steps:

1. Use a CAT5 UTP cable to connect port of Ethernet device to the DATA N port
2. Connect AC cable with Injector and Socket
3. Connect the PoE OUT port to a PD with CAT5 UTP cable.



Technical characteristics

Item	Description
Pass Through Data Rates	10/100/1000 Mbps
Pin Assignment and Polarity	1/2 (-), 3/6 (+)
Output Power Voltage	50VDC
User Port Power	15.4W /35W IEEE 802.3af/at Compatible
Input Power Requirements	AC Input Voltage: 100 to 240 VAC AC Input Current: 0. 5A 100-240 VAC AC Frequency: 50 to 60 Hz
Dimensions	145 mm x 60mm x 40mm
Indicators	System Indicator: AC Power User Indicator: Channel Power
Connectors	Shielded RJ-45, EIA 568A and 568B
Protection	Over current protection Over load protection Over voltage protection
Environmental Conditions	Operating Ambient Temperature:-10°C to 45°C Operating Humidity: Maximum 85%, Non-condensing Storage Temperature: :-1°C to 60°C Storage Humidity: Maximum 90%, Non-condensing

Ordering Information

SV-PSE-POE+	Starview 10/100/1000Base-T 1-port PoE+ Injector, with external AC power cord
-------------	--

Patch Panel



Starview 19-inch Rack-mount Fiber Optic Distribution Frame for FC,SC,ST,LC adapters. The enclosure is constructed of steel material and its front panel is designed to easily remove for cabling and connector installation.

Features

- Standard size, light weight and reasonable structure
- Compact design for space saving
- Front mark on the plate is easy for identification and operation
- Easy for management and operation
- Supports Multimode and Singlemode fiber splitting
- Wide Operating Temperature:
- From -40°C to 85°C
- High Reliability and Stability

Applications

- Transition from Backbone cabling to distribution switching
- Interconnect to active equipment in server cabinet
- Cross connect or inter-connect

Specifications

Type	Dimension	Max capacity	Remark
Drawer type 19" rack mounted	430mmx300mmx1U	SC/FC/ST 12	Cold rolled steel sheet, with electrostatic spraying, - suitable for FC,SC,ST,LC adapters. IP grade: IP20 ; compliant: ROHS
	430mmx300mmx1U	FC/ST 24	
	430mmx300mmx1U	2SC 48	
	430mmx300mmx2U	FC/ST 48	
	430mmx300mmx4U	2SC 144	

Ordering Information

Example:
CHASSIS-24SCUS-19R

Drawer type patch panel with 24 x SC simplex adapter, 19" 1RU Rack w/o pigtails.

- Type: Drawer type patch panel
- Cores: 12;24;48;96;
- Connector Type: SC:SC; LC:LC;
- Polishing Grade: U:UPC; A: APC
- Fibre Type: SM: Singlemode
MM: Multimode
- 19-inch Rack-mount
Fiber Optic Distribution Frame

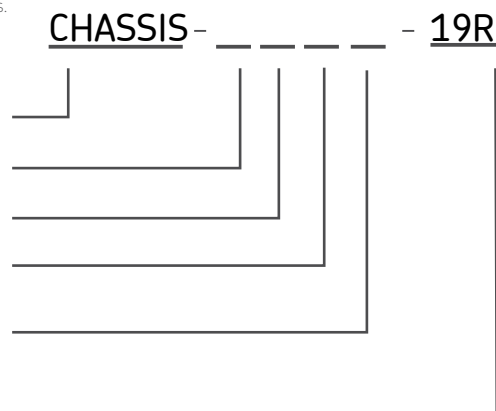

MPO Cassette



MPO Cassette
Management Panels



MPO Cassette Module

Starview 19-inch Rack-mount Fiber Optic Distribution Frame for FC,SC,ST,LC adapters. The enclosure is constructed of steel material and its front panel is designed to easily remove for cabling and connector installation.

MPO Cassette Module

The MPO Cassette modules provide the interface between the MPO on the trunk and the LC duplex and jumpers and that will then connect directly into the electronics.

Features

- Simple to use, convenient installation
- High density easy-plug cassette solution up to 96-fiber per 1U rack enclosure
- Improve cable manageability
- Pre-installed 12 or 24 fiber MPO adapter at the rear, choices of SC, LC adaptors at the front panel (faceplate)
- Can be pre-installed with factory-terminated & factory-tested MPO/MTP hydra assembly inside cassette module

Applications

- Data Center LAN/SAN

MPO Cassette Management Panels

MPO cassette management panel is designed to manage and house easy-plug MPO to LC fiber cassette modules, for connecting plug-and-play pre-terminated high density MPO Fiber cabling system. This solution contributes to greater network availability that especially suitable for SAN, LAN and Data Center applications. Each easy-plug MPO to LC cassette is accommodated with a 12/24-fiber MPO based fiber assemblies, and pre-loaded with LC adapters in different fiber modes for your choices

Features

- Up to 4 Small/MTP modules in 1U
- Multiple adaptor options available
- Accepts loose tube, distribution and pre-terminated cables
- ROHS, REACH SvHC and UL rated
- Fits standard 19"

Applications

- Data center
- Telecommunication networks

MPO Cassette Management Panels

Technical characteristics

U Size	Number of Ports	Dimension	Weight	Color	Designed in Accordance With
1U	4	482mm X 380mm X 44mm	3kg	Black	TIA/EIA 568.C, ISO/IEC 11801, EN50173, IEC60304, IEC61754,EN297-1

MPO Cassette Module

Technical characteristics

Fiber Type	Fiber Count	Number of Adapters per Panel	Adapter Type Front	Adapter Color Front	Adapter Type Back	Adapter Type Back
OM3/OM4	12/24	6	LC Duplex	Aqua/Purple	MPO	Black

Ordering Information

MPO Cassette Management Panels:

SV-CHASSIS-19C-4MPO

Starview 19" 1RU MPO rack mount enclosure suitable for 4 x MPO cassettes c/w equipment plunger mounting holes, rear entry for MPO cables, and front access for LC/UPC connectors

SV-CHASSIS-19C-12MPO

Starview 19" 1RU MPO rack mount enclosure suitable for 4 x MPO cassettes c/w equipment plunger mounting holes, rear entry for MPO cables, and front access for LC/UPC connectors

MPO Cassette Module:

Example:

SV-CASSETTE-24MPF12LCU-MM1MD24

Starview MPO cassette with MPO-24 (male) at rear panel and LC/UPC (female) at front panel, c/w pre-terminated MPO Breakout Fiber Optic cable, MPO-24 (female) to 12 x duplex LC/UPC (male) Multimode 50/125um 1 meter Duplex with type 2mm OM4 bend-insensitive fiber, and plunger for mounting to MPO rack mount enclosure

SV - CASSETTE -

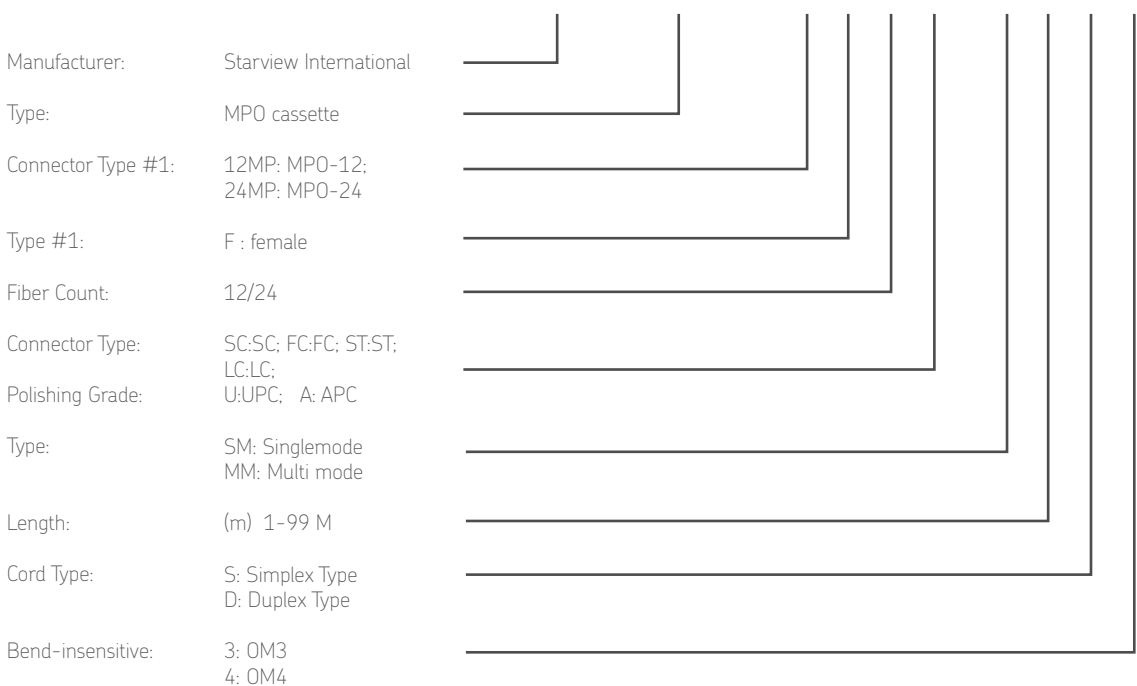

Maintenance Package for Transceiver Modules

Starview Maintenance package for transceiver modules provide value added RMA and advance replacement services to assist the customer's service operation, improve operational efficiency , and reduce the CAPEX and OPEX. We provide:

- Repair and Return(R&R)Service
- 24X7 spare parts replacement
- Logistical service for replacement

Starview maintenance package Repair & Return(R&R) process:

- Module will be one to one replaced on site or in starview office.
- Check the existing module performance characteristics.
- Ensure module performance within manufacturer's specifications.
- Replace module with Starview part if it is confirmed defective.
- Starview module warrant 2 years against manufacturing defect.
- Clean module TX/RX lenses if module is not defective.
- Return customer's module on the next two(2) business day.
- Starview warrants its replacement module to work with major equipment vendor

100GHz Spacing Wavelength

## ITU Channel	Wavelength	Frequency (THz)	## ITU Channel	Wavelength	Frequency (THz)	## ITU Channel	Wavelength	Frequency (THz)	## ITU Channel	Wavelength	Frequency (THz)
17	1563.86	191.7	40	1545.32	194.0	62	1563.86	191.7	91	1585.36	189.1
18	1563.05	191.8	41	1544.53	194.1	63	1563.05	191.8	92	1584.53	189.2
19	1562.23	191.9	42	1543.73	194.2	64	1562.23	191.9	93	1583.69	189.3
20	1561.42	192.0	43	1542.94	194.3	65	1561.42	192.0	94	1582.85	189.4
21	1560.61	192.1	44	1542.14	194.4	66	1560.61	192.1	95	1582.02	189.5
22	1559.79	192.2	45	1541.35	194.5	67	1559.79	192.2	96	1580.18	189.6
23	1558.98	192.3	46	1540.56	194.6	68	1558.98	192.3	97	1580.35	189.7
24	1558.17	192.4	47	1539.77	194.7	69	1558.17	192.4	98	1579.52	189.8
25	1557.36	192.5	48	1538.98	194.8	70	1557.36	192.5	00	1578.69	190.0
26	1556.55	192.6	49	1538.19	194.9	71	1556.55	192.6	01	1577.86	190.1
27	1555.75	192.7	50	1537.40	195.0	72	1555.75	192.7	02	1577.03	190.2
28	1554.94	192.8	51	1536.61	195.1	73	1554.94	192.8	03	1576.20	190.3
29	1554.13	192.9	52	1535.82	195.2	74	1554.13	192.9	04	1575.37	190.4
30	1553.33	193.0	53	1535.04	195.3	75	1553.33	193.0	05	1574.54	190.5
31	1552.52	193.1	54	1534.25	195.4	76	1552.52	193.1	06	1573.71	190.6
32	1551.72	193.2	55	1533.47	195.5	77	1551.72	193.2	07	1572.06	190.7
33	1550.92	193.3	56	1532.68	195.6	78	1550.92	193.3	08	1571.24	190.8
34	1550.12	193.4	57	1531.90	195.7	79	1550.12	193.4	09	1570.42	190.9
35	1549.32	193.5	58	1531.12	195.8	80	1549.32	193.5	10	1569.59	191.0
36	1548.51	193.6	59	1530.33	195.9	81	1548.51	193.6	11	1568.77	191.1
37	1547.72	193.7	60	1529.55	196.0	82	1547.72	193.7	12	1567.95	191.2
38	1546.92	193.8	61	1528.77	196.1	83	1546.92	193.8	13	1567.13	191.3
39	1546.12	193.9				84	1546.12	193.9	14	1566.31	191.4
						89	1587.04	188.9	15	1565.50	191.5
						90	1586.20	189.0	16	1564.68	191.6

50GHz Spacing Wavelength

## ITU Channel	Wavelength	Frequency (THz)
17	1563.86	191.70
17.5	1563.45	191.75
18	1563.05	191.80
18.5	1562.64	191.85
19	1562.23	191.90
19.5	1561.83	191.95
20	1561.42	192.0
20.5	1561.01	192.05
21	1560.61	192.10
21.5	1560.20	192.15
22	1559.79	192.20
22.5	1559.39	192.25
23	1558.98	192.30
23.5	1558.58	192.35
24	1558.17	192.40
24.5	1557.77	192.45
25	1557.36	192.50
25.5	1556.96	192.55
26	1556.55	192.60
26.5	1556.15	192.65
27	1555.75	192.70
27.5	1555.34	192.75
28	1554.94	192.80
28.5	1554.54	192.85
29	1554.13	192.90
29.5	1553.73	192.95
30	1553.33	193.0
30.5	1552.93	193.05
31	1552.52	193.10

## ITU Channel	Wavelength	Frequency (THz)
31.5	1552.12	193.15
32	1551.72	193.20
32.5	1551.32	193.25
33	1550.92	193.30
33.5	1550.52	193.35
34	1550.12	193.40
34.5	1549.72	193.45
35	1549.32	193.50
35.5	1548.91	193.55
36	1548.51	193.60
36.5	1548.11	193.65
37	1547.72	193.70
37.5	1547.32	193.75
38	1546.92	193.80
38.5	1546.52	193.85
39	1546.12	193.90
39.5	1545.72	193.95
40	1545.32	194.0
40.5	1544.92	194.05
41	1544.53	194.10
41.5	1544.13	194.15
42	1543.73	194.20
42.5	1543.33	194.25
43	1542.94	194.30
43.5	1542.54	194.35
44	1542.14	194.40
44.5	1541.75	194.45
45	1541.35	194.50
45.5	1540.95	194.55

## ITU Channel	Wavelength	Frequency (THz)
46	1540.56	194.60
46.5	1540.16	194.65
47	1539.77	194.70
47.5	1539.37	194.75
48	1538.98	194.80
48.5	1538.58	194.85
49	1538.19	194.90
49.5	1537.79	194.95
50	1537.40	195.0
50.5	1537.00	195.05
51	1536.61	195.10
51.5	1536.22	195.15
52	1535.82	195.20
52.5	1535.43	195.25
53	1535.04	195.30
53.5	1534.64	195.35
54	1534.25	195.40
54.5	1533.86	195.45
55	1533.47	195.50
55.5	1533.07	195.55
56	1532.68	195.60
56.5	1532.29	195.65
57	1531.90	195.70
57.5	1531.51	195.75
58	1531.12	195.80
58.5	1530.72	195.85
59	1530.33	195.90
59.5	1529.94	195.95
60	1529.55	196.0
60.5	1529.16	196.05

Calculating Fiber Loss & Distance Estimates

Estimate Total Link Loss

This calculation will estimate the total link loss through a particular fiber optic link where the fiber length, as well as the number of splices and connectors, are known. This calculation is simply the sum of all worst-case loss variables in the link:

$$\text{Link Loss} = [\text{fiber length (km)} \times \text{fiber attenuation per km}] \\ + [\text{splice loss} \times \text{\# of splices}] \\ + [\text{connector loss} \times \text{\# of connectors}] + [\text{safety margin}]$$

For example: Assume a 40 km single mode link at 1310nm with 2 connector pairs and 5 splices.

$$\text{Link Loss} = [40 \text{ km} \times 0.4 \text{ dB/km}] + [0.3 \text{ dB} \times 5] + [0.75 \text{ dB} \times 2] + [3.0 \text{ dB}] = 21.0 \text{ dB}$$

In this example, an estimated 21.0 dB of power would be required to transmit across this link. Of course, it is very important to measure and verify the actual link loss values once the link is established to identify any potential performance issues.

Estimate Fiber Distance

This calculation will estimate the maximum distance of a particular fiber optic link given the optical budget and the number of connectors and splices contained in the link:

$$\text{fiber Length} = \frac{[\text{Optical budget}] - [\text{link loss}]}{[\text{fiber loss/km}]}$$

$$\text{Fiber Length} = \frac{\{[(\text{min. TX PWR}) - (\text{RX sensitivity})] - [\text{splice loss} \times \text{\# of splices}] \\ - [\text{connector loss} \times \text{\# of connectors}] - [\text{safety margin}]\}}{[\text{fiber loss/km}]}$$

For example: Assume a Fast Ethernet Single mode link at 1310nm with 2 connector pairs and 5 splices.

$$\text{Fiber Length} = \frac{[26.0 \text{ dB}] - [0.5 \text{ dB}] - [1.5 \text{ dB}] - [3.0 \text{ dB}]}{[0.4 \text{ dB/km}]} = 52.5 \text{ km}$$

$$\text{Estimate fiber link budget(dB)} = \text{Tx Power}(\text{min}) - \text{Rx sensitivity}(\text{max})$$

$$\text{Estimate fiber link distance(km)} = \text{Link budget} / \text{Fiber attenuation}^*$$

*Multimode fiber needs to add 3dB link margin

In this example, an estimated 52.5 km distance is possible before dissipating the optical power to a value below the RX sensitivity. As always, it is very important to measure and verify the actual link loss values once the link is established to identify any potential performance issues. Actual maximum distances will very depending on:

- Actual optical fiber attenuation per km
- Optical fiber design and age
- Quality of connectors and actual loss per pair
- Quality of splices and actual loss per splice
- Quantity of splices and connectors in the link

Calculating Fiber Loss and Distance Estimates

Fiber Type	Wavelength	Fiber attenuation / km*	Fiber attenuation / km #	Connector Loss	Splice Loss
Multimode 50/125 μm	850nm	3.5 dB	2.5 dB	0.75 dB	0.3 dB
	1300nm	1.5 dB	0.8 dB	0.75 dB	0.3 dB
Multimode 62.5/125 μm	850nm	3.5 dB	3.0 dB	0.75 dB	0.3 dB
	1300nm	1.5 dB	0.7 dB	0.75 dB	0.3 dB
Single Mode 9 μm	1310nm	0.4 dB	0.35 dB	0.75 dB	0.3 dB
Single Mode 9 μm	1550nm	0.3 dB	0.22 dB	0.75 dB	0.3 dB

*These values are per TIA/EIA and other industry specifications and are the values used by Starview International in all link loss calculations.

#These values are one example of the performance that can be obtained with a new fiber installation.

Fiber Optic Definitions

Maximum Transmit Power

The maximum output power in dBm(decibels relative to 1mW) of the optical transmitter/transceiver.

Minimum Transmit Power

The minimum output power in dBm (decibels relative to 1mW) of the optical transmitter/transceiver.

Launch Power

The actual output power in dBm (decibels relative to 1mW) of the optical transmitter/transceiver. This value will reside somewhere within the max. and min. transmit power levels listed.

Receive Sensitivity

The minimum input power in dBm (decibels relative to 1mW) necessary to correctly drive the optical receiver.

Maximum Receive Power

The maximum input power in dBm (decibels relative to 1mW) the optical receiver can safely accept without overdriving the receiver.

Link Budget

The amount of power available for dissipation over the fiber link between end devices. It is calculated using worst case assumptions by subtracting the receive sensitivity from the minimum transmit power.

Link Loss

The total amount of power dissipation over the fiber link between end devices. It is calculated using maximum loss values for distance, splices and connectors.

Splice Loss

The amount of power loss attributable to a fiber optic spliced connection.

Connector Loss

The amount of power loss attributable to a fiber optic connector pair.

Attenuation

The amount of power loss per kilometer over the fiber link. Attenuation is wavelength specific and will depend greatly on type and condition of the optical fiber found in the link.

Safety Margin

It is common practice to add a couple of dB loss as a safety buffer to account for items such as fiber aging, splice and connector degradation over time and environmental factors such as temperature and humidity.

The IEEE also recommends maximum cable distances as defined in the table below:

Standard	Data Rate (Mbps)	Cable Type	IEEE Standard Distance
10BASE-FL	10	850nm Multimode 50/125 μ m or 62.5/125 μ m	2 km
100BASE-FX	100	1300nm Multimode 50/125 μ m or 62.5/125 μ m	2 km
100BASE-SX	100	850nm Multimode 50/125 μ m or 62.5/125 μ m	300 m
1000BASE-SX	1000	850nm Multimode 50/125 μ m	550 m
		850nm Multimode 62.5/125 μ m	220 m
1000BASE-LX	1000	1300nm Multimode 50/125 μ m or 62.5/125 μ m	550 m
		1310nm Single mode 9/125 μ m	5 km
1000BASE-LH	1000	1550nm Single mode 9/125 μ m	70 km

Starview International assumes the multimode standard distances defined by IEEE for all of its products.

Transceivers FAQ

1. What is the difference between Starview International SFP and Original Vendor SFP?

In reality, there is no difference. Original vendor SFP are much higher in cost as they claim to be of much better quality. Most if not all, network equipment vendors do not produce their own SFP modules. These productions are outsourced to contract manufacturer and then labeled as their specific brand

2. Is it true that key equipment vendors, such as Cisco and Alcatel, only allow their SFP ports to be used by their in-house modules?

No, vendors are supposed to allow third party SFP to be used on their equipment as the SFP transceiver is specified by a multi-source agreement (MSA) between competing vendors. MSA specifies the physical dimensions, connectors, and signaling used in the SFP module so that multiple vendors can build compatible products at competitive costs. All Starview International SFP are produced with high precision in conjunction to the MSA and are compatible to use on equipments specified as a SFP port.

See the SFF committee's INF-8074i specification Rev 1.0 for details. Please note that Starview International SFP is not the vendor's OEM brand SFP modules.

3. How do we define a good quality SFP?

It is a misconception that SFP depends only on optical budget. Stability and reliability is an important aspect. The performance of the optical specifications changes with temperature and aging due to time. During production, it is possible for manufacturers to increase the optical budget by purposely adjusting the optical transmit power during the calibration process. This cause the TOSA to over-perform and will have a significant impact on the stated SFP lifespan.

Our factory produces all individual components required in the SFP modules, including the TOSA and ROSA. Every stage of the SFP assembly undergoes strict quality assurance policy with uncompromising standards. Design considerations of each SFP modules are done by experienced R&D engineers in this field. We are able to provide full detailed test reports, for each product part number, with optical budget measurement, digital eye diagrams, MTBF and thermal chamber test.

4. Why some third-party SFP "refuse" to work on the equipment when the original SFP from the same equipment vendors work fine?

SFP enjoys such a huge popularity success in the industry that certain equipment vendors attempt to prevent their customers from making choices. The firmware in the equipment will check for an identifying data in the SFP's memory, and if the data does not belong to the equipment vendor, the equipment refuses to enable that slot. Most vendor explanation for this "feature" is that it represents a symbol of product quality and ensures that the transceiver module is certified and tested by the original vendors.

The original idea of having "ID" in the SFF-8472 was actually meant for network management software to 'inventory' the pluggable modules. However some vendors used this to lock out all other third party. This allows vendor to monopolize the transceivers for their equipment and charge at premium prices for "better" quality products.

5. Can end-user re-use Starview International SFP on other equipment vendor after first using the SFP on a particular equipment vendor?

Yes. As Starview International is the original SFP manufacturer, we have the equipment and technical know-how to reprogram the data in the SFP, if necessary, to be compatible with a new equipment vendor. This can be performed for a nominal sum of fee. Please contact our sales staff for more information on this.

Please note that Starview International SFP is not the vendor's OEM brand SFP modules.

6. Does using Starview International SFP voids the warranty of the equipment it is used on?

No. If the equipment is defective, the vendors are obliged to fulfill the terms of the warranty because Starview International SFP are fully compliant to MSA, unless it can be verified that it is the use of Starview International SFP that damaged the equipment.

It is unlikely that SFP will induce damages to the slot on equipment by itself because:

- SFP converts electrical data from the equipment to optical signal. There is no incoming power surge from optical ports to damage the equipment.
- SFP draws voltage/power from the equipment and it is more likely that the equipment damaged the SFP. All current and voltage required are as per MSA and the equipment should be able to support the power requirements for each SFP ports.
- SFP size will fit accordingly to any MSA compliant device without damaging the electrical circuitry on the equipment.
- If installations of SFP modules are handled by personnel who are properly grounded, there is no electrostatic damage to the equipment circuitry.

Some vendor does try to protect the sales revenue of their SFP by denying support if the serial number does not match their record. In this case, Starview International will offer tech support if it is a physical layer 1 problem. If the problem is not on the physical layer but exists on a higher protocol layer, it is your right as a customer to demand support from the equipment vendor.

7. What is the warranty coverage for using Starview International SFP?

Starview International SFP offers standard 2 year warranty. Extended warranty and maintenance services are available. It may be interesting to note that some vendors such as Cisco offers only 90days warranty on their SFP.

8. Why should customers consider using Starview International?

Key advantages that Starview International can bring to our customers are price competitiveness, quality/reliable, fast response, compatibility, large range of optical transceivers, quick lead time and maintenance services.

In addition, as most network equipment vendors do not produce the SFP themselves, the range of optics options they are able to produce are limited. Cisco offers only 8 CWDM wavelengths instead of 16. Cisco also does not have single fiber solution for more than 10km. Starview International offers much more complete optics options for project needs.

9. Why Starview International can offer Starview International SFPs at much lower cost than the original hardware vendors?

In reality, most if not all, network equipment vendors do not produce their own SFP modules. The productions are outsource to contract vendors and labeled as their specific brand. Hence, these SFP are higher in cost because of additional margins at each party.

Starview International is an in-house product for Starview International with our production house in China. This allows end-user to bypass the in-between parties and allow customer to purchase straight from the production source. We also have a large customer base and are able to mass produce at a cost-effective level.

10. Why are there some SFP suppliers on the market who are able to provide at more competitive prices?

In general, these suppliers with ultra-low cost SFP have low regards for quality as they take their SFP from sources that provide the lowest price. The specifications for their SFP may keep varying as to what is stated as the source of their SFP depends on price and they have 2-3 suppliers for the same product. Some possible sources of ultra-low cost SFP comes below.

- Some factory source low-grade components from different parties and only performs assemblies. The finished products are of varying quality and have no strict quality control as they lack necessary test tools.
- Contract manufacturers tend to over produce the required amount during production to replace out the low quality yields. Some customer may also return rejected batches which failed to meet their expectations. The "leftover" pieces are consolidated and released to companies with low budgets.
- Purchase of stocks that are kept over an extended period of time.
- Refurnished/RMA products that are repackaged and sold as brand-new

These suppliers also have unusual huge amount of stocks and are able to deliver at any time. In truth, manufacturers produce on demands or forecast and keep only limited stocks on fast-moving products.

11. Other than SFP, what other form factors does Starview International offers?

Starview International provides form factors modules such as GBIC, SFP, SFP plus, Xenpak, X2 and XFP. QSFP for 40G data-rate are also available.

In addition, we can offer a wide range of transceivers supporting protocols such as FE/GE, Fiber-Channels, SDH/SONET, 10GE and 40G. Optics options include single-fiber, SGMII, PON, CWDM/ DWDM.

12. What is the typical lead-time for Starview International SFP?

7-14 days depending on the requested items and quantities. We are also able to produce and keep in stock if there is a committed forecast from the customer.

13. How do I choose a SFP for my application?

Basic key considerations when selecting an SFP are as followings:

- Protocol/data rate used on the equipment
- Optical transmitting wavelength preference
- Optical transmission distance. Note: 60km and above, we recommend user to specify the optical budget required for the link instead.
- Type of fiber used: Singlemode /Multimode, Dual Fiber/Single Fiber
- Form Factor: GBIC, SFP*, SFP+,XFP, etc
- DDM preference

For other unique application, please contact our sales staff.

* Please note that SFP is also commonly known as mini-gbic.

14. What is Digital Diagnostic Monitoring (DDM) feature?

DDM is also known as digital optical monitoring (DOM) or Digital Monitoring Interface (DMI). Modern optical SFP support DDM functions according to the industry-standard SFF-8472. The SFP MSA defines a memory map describing the transceiver's capabilities, standard interfaces, vendor, and other information. This feature gives the end user the ability to monitor real-time parameters of the SFP, such as optical output power, optical input power, temperature, laser bias current, and transceiver supply voltage.

15. Is a SFP module hot swappable?

Yes, Starview International SFP is hot swappable, however, the equipment SFP port must be specified as hot-swappable as well. Please note that some equipment such as Cisco takes some time enable the physical port after inserting a new module. Also, when the physical module is removed, the equipment may enter a error disable state for a configurable period of time ranging from 30sec to 24hours. During the error disable period, even when the fault is recovered, the data link cannot be established. The results are the same even if you use the original vendor version of SFP.

16. Is SFP protocol transparent?

SFP are totally transparent to Ethernet/IP protocols and have no constraint on the transmission frame size. All Starview International SFP supports wire-rate data transmission at full-duplex mode. Higher layer level protocol issues are restricted to the equipment itself.

The reason is because SFP connects to the electrical circuitry of the equipment and only converts electrical data to an optical signal with no modifications in the protocol/frames. Hence, SFPs are operating solely on physical layer translation but the SFP in use must match the data-rate of the protocol specified on the equipment SFP port.

However, the use of poor quality SFP does induces additional transmission errors on the optical port such as CRC, frame slip, jitter, bit-error, etc. This is exceptional true on long distance transmission.

17. How do you reprogram the CISCO switches?

The following procedure is offered on a trial basis and is not guaranteed to work successfully on all CISCO switches and firmware revisions. It is recommended that you update the firmware on the switch first to make sure the latest revision is installed, increasing the likelihood of success with this procedure. The switch model tested are 2960, 2970G, 3560, 3560G, 3750.

- a. Connect to the switch console port and log on in "enabled" mode to allow privileged commands
- b. Once enabled, enter "config t" to allow configuration from the terminal
- c. Specify which port you would like to configure by entering the command "Interface Gigabit ?/?" where ?/? is the unit and port number you are trying to re-configure
- d. After entering that information, enter "service unsupported-transceiver"
- e. Enter "Shutdown". The switch will respond with a message stating that the port is administratively down.
- f. Enter "no shutdown". You may get a warning(s) about using "Unsupported Transceivers", but once the messages are done, the port will come online and function normally with the Starview international SFP.

STARPOD FAQ

1. Why is it called STARPOD?

STARPOD stands for Starview Programmable Optical Device. It allows programming of the Starview Transceiver modules remotely by the user themselves. Traditionally all Transceiver modules are programmed in factory during production. However when user decides to change or upgrade their network equipment to a different vendor, the transceiver module is not reusable.

2. Who are the main users of STARPOD?

STARPOD is suitable for all network users that uses Transceiver modules in their networking devices. STARPOD gives them the flexibility and versatility of deploying Transceiver modules to any of their network equipment, thus saving time and money. Nowadays Transceiver modules form a major cost to the total Cost of Ownership. STARPOD has the potential to overcome the cost of investment and allows flexibility of usage of the transceiver modules to work with any manufacturers' networking equipment.

3. What are the advantages of using STARPOD?

The advantages of using STARPOD are:

- a) Allows flexibility of reprogramming Starview transceiver modules remotely
- b) Faster response time to integrate the existing transceiver modules to support various network equipment
- c) Better Return of Investment for Transceiver modules
- d) Ease of use and do not require any trained personnel

4. What is the use of STARPOD?

STARPOD allows programming of the Starview Transceiver module to work with major equipment vendor. Most of the Network Equipment Vendor will encode information into the EEPROM of the Transceiver module so that it will reject any 3rd party devices. STARPOD is able to decode and overwrite the information into the EEPROM of the Starview Transceiver module so that these Network Equipment vendors will see the Transceiver module corresponds to their equipment coding to work normally.

5. What are the equipment vendors supported by STARPOD?

STARPOD supports equipment coding such as CISCO, Juniper, Alcatel Lucent, Extreme Networks, Huawei, Force 10, ZTE, HP, Arista Networks, ADVA Optical Networking, BTI, Intel, EXFO, JDSU, ATI, Tellabs NSN, Netscount, Brocade, Adtran, Ericsson, RAD, Avaya, Cyan and many more. If the equipment is not within this list, Starview is able to decode an original transceiver module to re-program into the Starview transceiver module.

6. Does STARPOD only support Starview Transceiver modules?

Every manufacturer has their own password protection on their transceiver modules. Likewise Starview has our own password protection of our EEPROM embedded in the Transceiver module. The password protection on the EEPROM is to disallow any change of the Transceiver information by unauthorized access. Hence the STARPOD can only be programmed the Starview Transceiver modules, or any other Transceiver modules that does not have password protection on their EEPROM.

7. How does STARPOD do the reprogramming of the Transceiver module?

The user must ensure that the STARPOD is connected to the computer and has a valid internet link. During the operation of STARPOD, the device will tally the transceiver module part number and serial number with our Starview database via the internet link. This is to ascertain that it belongs to the part of our production supply. Upon successful matching with our database, the transceiver coding will then be downloaded from the internet and be programmed into the EEPROM.

8. What must the user do at first when they want to re-program the Transceiver module?

The user must send a request via email or telephone call to any of our Starview authorized agent or reseller to provide the following information:

- Equipment vendor and part no of the Network Equipment to be used
- Part no and Serial no of the transceiver module to be reprogrammed

Upon receiving this information, a license key shall be generated within the same business day. The Starview authorized agent or reseller will contact the user and send the license key via email. The user will simply key in the license key via the STARPOD software to download the equipment coding into the transceiver module. The reprogramming process will take less than 1 minute.

9. What happens if the user wants to revert to the previous coding or if the coding that was sent will not work in the networking equipment?

Should the user wants to revert to the previous code, the same process of requesting the license key apply. Each license key is only valid for one time use, and is not reversible. If the coding programmed into the transceiver module does not work, Starview will resend the license key (not chargeable) to ensure that the transceiver module works with the vendor's network equipment unit. Else money back will be guaranteed.

10. How does the license key works?

The license key can be purchased via the Starview authorized agent or reseller in advance or at the point of usage. It comes at the price of 1, bundle of 10 and bundle of 100. The license keys will be tracked by Starview International when it is used. Each license key is valid for only 1 equipment coding. The license key is only valid as a one-time usage. When the user requests for the equipment coding, Starview will upload the code into the cloud encrypted by a license key. Each license key will carry the coding information of the network equipment vendor, part no and serial no of the transceiver module to be re-programmed, and it is stored inside the network cloud. Once the license key is used, it will not be able to reuse.

11. Does STARPOD re-programming require that the Starview Transceiver module remains under warranty?

No. STARPOD does not require that the Starview transceiver module is within the warranty period in order to do re-programming. As long as the Transceiver module is still in good working condition, the STARPOD is use to access the EEPROM to program the transceiver module to work with the network equipment vendor.

12. What is the difference between STARPOD and other manufacturer's programming board?

STARPOD provides a license key to download the complete coding file into the EEPROM of the Starview transceiver module. It overwrites the existing file completely. Other manufacturer's programming board requires user to check the HEX code at each manufacturer's code destination in the EEPROM file, and change it manually. In addition, there is a checksum to ensure that it corresponds to Vendor's network equipment. Overall it takes a lot of understanding to study the coding in the EEPROM file.

13. Why Starview is able to decode so many manufacturers' network equipment coding while others are not?

Starview has a team of trained engineers with many years of experience to decode the manufacturers' network equipment code. We have understood the mechanism of various network equipment manufacturers on their coding process and is able to re-construct the coding into our STARPOD. Other competitors may have a NDA signed with the original manufacturer, or does not have trained engineers to understand the codes.

14. What are the modules supported by STARPOD?

Currently STARPOD supports SFP, SFP+ and XFP transceiver modules. STARPOD does not matter if the transceiver module is copper, Singlemode, multimode or WDM. STARPOD will re-program the EEPROM in these transceiver modules as long as it is supported by the form factor.

15. Can STARPOD be used on Apple computers?

Currently STARPOD only works on Windows platform and it is not supported by Apple.

16. Does STARPOD affect the transmission characteristics of the Transceiver module?

No. STARPOD only accesses the information in the EEPROM and does not affect the configurations of the TOSA and ROSA components of the Transceiver module.

17. How does the user know the functionality of the Transceiver module is End of Life (EOL)?

STARPOD is not able to determine the EOL of the transceiver module. It basically re-programs the coding of the transceiver module EEPROM to work with the vendor's networking equipment.

18. How is STARPOD information or software upgrade being updated?

All STARPOD information shall be updated in our website <http://www.starviewint.com> whenever a new update is released. The Starview authorized agent or reseller will constantly be updated on any new release and these information will be sent to the user..

Transceiver 3rd Party FAQ

1. What are 3rd party transceiver modules?

3rd party transceiver modules originate from manufacturers who are Original Equipment Manufacturers (OEMs) that supplies to brand owners such as Cisco, Juniper, HP, Huawei, ALE etc. None of these brand owners manufactures their own transceivers, but relabel them for resale.

2. Why can some OEMs make cheap transceivers?

There is always a huge margin on transceivers made by the big brand owners. For the same quality of transceivers, sourcing direct from the OEM saves money. Among the OEMs, prices can also vary widely. Different OEMs sources have different quality and prices of components; have different manufacturing processes and different quality control processes. This will invariably result in different quality of end products, e.g. without proper heat dissipation or EMI isolation. It is important to source transceivers from reliable OEMs. Some low-quality transceivers have short life spans, and may last just 1 to 2 years, just enough for the warranty period to expire. We have also found smaller OEMs repackaging used transceivers to be sold as new, or lower manufacturing QC or specifications to increase manufacturing yield. Caveat emptor!

3. I can find many online websites that offer transceivers at affordable prices and ready stocks. Are they reliable?

Prices and stocks can readily be available from the internet. However, you cannot be sure of the quality or reliability. Many of these sites are not operated by the OEMs. You buy at your own risks. You must also know what you are buying, because product returns may not be offered, or even if they are offered, you have to pay for return shipping which is often expensive. Transceivers have firmware built-in, so technical support is crucial when things do not work. Communication and language is another issue when the supplier is not proficient in English.

4. I have a reliable agent in China who sources direct from OEMs. Why should I source from Starview?

Great that you have a reliable agent, because you may not have direct access to the OEM because you cannot commit to high volumes. Just make sure that they do not change the source OEM without your knowledge, and that they are able to provide after-sales technical support if things do not work.

5. The transceivers are so cheap. Isn't it better to replace them with new ones when they do not work?

In the first place, transceivers should last their intended life-span of at least 5 years. When good quality transceivers do not work after deployment, it is usually the result of contaminated optics between the path of transmitter to receiver. A good engineer should have the proper tools to find and clean the source of the contamination.

6. I just want the lowest price and do not care about the support

Due to industry competitiveness, prices are still the main decisive factor. However if you consider the Total Cost of Ownership (TCO), savings on CAPEX can eventually result in higher OPEX, e.g. engineering support, traveling and downtime. Choosing a reliable vendor with good after-sales support will eliminate many technical issues later

7. I am offered a programming board. Isn't this similar to STARPOD?

The programming board is used to alter the firmware of the transceivers. This is a very low level board down to bit and bytes in the registers. It requires very deep technical knowledge to operate the boards. STARPOD is designed by STARVIEW to simplify the entire process. It can be used by any field engineer with very little training. It can also be used in the field as a diagnostic tool to allow STARVIEW to provide remote support in a timely fashion.

8. Why should I consider Starview when there are so many vendors out there that I can easily purchase the modules?

Starview is based in Singapore, and is reputable company supplying reliable transceiver modules to major customers such as telecom operators and large data centers. Starview can offer up to 5 years warranty, with good technical knowledge and efficient after-sales support. Starview also has the knowledge to advise customer on the correct transceiver module to use, as well as the expertise to provide interoperability of transceiver modules to work with major networking equipment.

9. What can I gain by using Starview transceiver modules comparing with those I get from other vendors?

- a) Excellent 24x7 technical support and after-sales service
- b) Trouble ticketing system to log customer's issue, which the customer can share with their other engineers in future
- c) Remote diagnostic tool to capture the module interoperability issue
- d) Competitive prices and fast delivery lead time
- e) Wide choice of transceiver modules to select
- f) Ease of mind during deployment and troubleshooting
- g) Strong references with major telcos/ data centers
- h) MSA compliant Transceiver modules
- i) Reprogramming of the modules can be done on site by untrained/ non-technical personnel to interwork with various networking equipment vendors
- j) Starview is a solution provider that can complement many other networking products as a niche and cost effective solution

10. I am happy with my current vendor and have no problem using them

Great!! If at any time you are reconsidering another source, please keep us in mind.

www.starviewint.com

version4.0

Value-Added Resellers

